

無限コーティング プレミアム
ロングネック エンドミルシリーズ

MHRH230	MHRH430
MRBH230	MACH225
MRBTNH230	MRBTNH345
MHRH230R	MHRH430R



型番 Model	サイズ Size	最大加工深さ Maximum Cutting Depth	コーティング Coating	刃数 Number of Flute	ねじれ角 Helix Angle	側面加工 Side Milling	溝加工 Slot Milling	平面加工 Face Milling	曲面加工 3D Milling	対応被削材 Work Material											サイズ数 Number of Sizes	ページ Page
										P P P M N N N N S H	炭素鋼 Carbon Steel	40HRC Austenitic Steel	50HRC Prehardened Steel	ステンレス鋼 Stainless Steel	アルミ Aluminum Alloy	銅 Copper	樹脂 Resin	グラファイト Graphite	硬質合金 Hard Brittle Material	耐熱合金 Heat Resistant Alloy etc		
ロングネックスクエア Long Neck Square																						
MHRH230	φ0.1 ~ φ3	25D	∞ Premium	2	30°	Side Slot	Face	-	-	-	○	○	-	-	-	-	○	○	-	134	G-004	
調質鋼・高硬度鋼（～65HRC）対応のロングネックスクエアエンドミル。L/Dは最大25倍 Long neck square end mill for hardened steels up to 65HRC. Maximum L/D=25																						
MHRH430	φ1 ~ φ6	≒10D	∞ Premium	4	30°	Side Slot	Face	-	-	-	○	○	-	-	-	-	○	○	-	55	G-010	
調質鋼・高硬度鋼（～65HRC）対応の4枚刃ロングネックスクエアエンドミル。L/Dは最大約10倍 4-flute long neck square end mill for prehardened steels and hardened steels up to 65HRC. Maximum L/D=10																						
ロングネックボール Long Neck Ball																						
MRBH230	R0.05 ~ R3	22D	∞ Premium	2	30°	-	-	-	3D	-	○	○	-	-	-	-	○	○	-	224	G-014	
調質鋼・高硬度鋼（～65HRC）対応のロングネックボールエンドミル。L/Dは最大22倍 Long neck ball end mill for prehardened steels and hardened steels(～65HRC). Maximum L/D=22																						
MACH225	R0.1 ~ R3	6D	∞ Premium	2	25°	-	-	-	3D	-	○	○	-	-	-	-	○	○	-	26	G-026	
鋭い刃先で切削負荷を軽減し靱性の高い被削材に対応 Sharp cutting edge reduces cutting load for tough materials																						
テーパネックボール Long Neck Tapered Ball																						
MRBTNH230	R0.05×首角3° ～R2×首角1° R0.05×neck taper angle3° ～R2×neck taper angle1°	30D	∞ Premium	2	30°	-	-	-	3D	-	○	○	-	-	-	-	○	○	-	209	G-028	
テーパネックの採用で工具剛性が大幅アップ。加工面の傾斜角と同じ角度の首角が使えます Taper neck to improve tool rigidity. Option of same taper angle as inclined working angle																						
MRBTNH345	R0.5×首角30° ～R2×首角1° R0.5×neck taper angle30° ～R2×neck taper angle1°	30D	∞ Premium	3	45°	-	-	-	3D	-	○	○	-	-	-	-	○	○	-	69	G-036	
3枚刃強ねじれとテーパネックの採用で深部の加工を高効率に 3-flute with high helix angle and taper neck design for deep area milling with high efficiency																						
ロングネックラジアス Long Neck Corner Radius																						
MHRH230R	φ0.2 × R0.02 ～φ0.9 × R0.1	≒16D	∞ Premium	2	30°	Side Slot	Face	-	-	-	○	○	-	-	-	-	○	○	-	97	G-040	
調質鋼・高硬度鋼（～65HRC）対応のロングネックラジアスエンドミル。L/Dは最大約16倍 Long neck corner radius end mill for prehardened steels and hardened steels(～65HRC). Maximum L/D=16																						
MHRH430R	φ0.1 × R0.01 ～φ6 × R1	16D	∞ Premium	4	30°	Side Slot	Face	-	-	-	○	○	-	-	-	-	○	○	-	336	G-044	
調質鋼・高硬度鋼（～65HRC）対応の4枚刃ロングネックラジアスエンドミル。L/Dは最大約16倍 4-flute long neck corner radius end mill for prehardened steels and hardened steels(～65HRC). Maximum L/D=16																						

MHRH230

サイズ
Size $\phi 0.1 \sim \phi 3$



無限コーティングプレミアム 高硬度用2枚刃ロングネックエンドミル

MUGEN COATING PREMIUM 2-Flute Long Neck End Mill for Hardened Steel

調質鋼・高硬度鋼 (～65HRC) 対応の
ロングネックスクエアエンドミル。L/Dは最大25倍

Long neck square end mill for hardened steels up to 65HRC. Maximum L/D=25

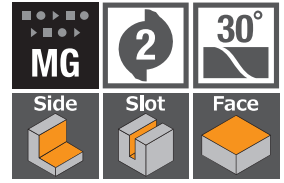

- プリハードン鋼 P
Prehardened Steel
- ステンレス鋼 M
Stainless Steel

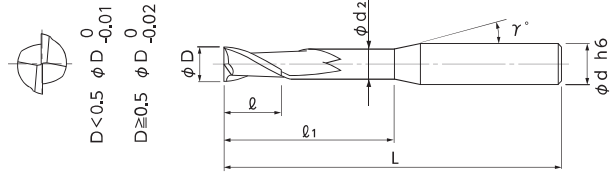

- 無限コーティングプレミアムの採用により、高硬度鋼の加工に長寿命！加工精度も向上！
- 全134サイズ！
- MUGEN COATING PREMIUM to improve accuracy and tool life on machining hardened steels!
- Total 134 sizes!

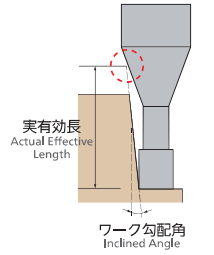

単位 [寸法: mm / 価格: 円]
Unit [Size: mm / Retail Price: JPY]

コードNo. Code No.	(D)外径 Dia.	(l1)首下長 Under Neck Length	(l)刃長 Length of Cut	(d2)首下径 Neck Dia.	(γ)首角 Neck Taper Angle	(d)シャック径 Shank Dia.	(L)全長 Overall Length	標準価格 Retail Price	ワーク勾配角に対する実有効長 Actual effective length depending on inclined angle of workpiece.				
									30°	1°	1°30'	2°	3°
08-00207-01003	0.1	0.3	0.08	0.085	12°	4	45	10,500	0.35	0.37	0.38	0.40	0.45
08-00207-01005		0.5					0.56	0.58	0.61	0.64	0.71		
08-00207-01007		0.75					0.82	0.86	0.90	0.94	1.05		
08-00207-01010		1					1.08	1.13	1.18	1.24	1.38		
08-00207-01503	0.15	0.3	0.12	0.13	12°	4	45	9,700	0.36	0.38	0.40	0.42	0.46
08-00207-01505		0.5					0.57	0.60	0.62	0.66	0.73		
08-00207-01507		0.75					0.83	0.87	0.91	0.96	1.06		
08-00207-01510		1					1.09	1.14	1.20	1.25	1.39		
08-00207-01515	0.15	1.5	0.12	0.13	12°	4	45	11,500	1.09	1.14	1.20	1.25	1.39
08-00207-01515		1.5					1.61	1.69	1.77	1.85	2.06		
08-00207-02005		0.5					0.57	0.60	0.62	0.66	0.73		
08-00207-02007		0.75					0.83	0.87	0.91	0.96	1.06		
08-00207-02010	0.2	1	0.15	0.18	12°	4	45	7,800	1.09	1.14	1.20	1.25	1.39
08-00207-02015		1.5					1.61	1.69	1.77	1.85	2.06		
08-00207-02020		2					2.13	2.23	2.34	2.45	2.72		
08-00207-02025		2.5					2.66	2.78	2.91	3.05	3.39		
08-00207-02030	0.2	3	0.15	0.18	12°	4	45	11,000	3.18	3.32	3.48	3.65	4.06
08-00207-03010		1					1.09	1.14	1.20	1.25	1.39		
08-00207-03015		1.5					1.61	1.69	1.77	1.85	2.06		
08-00207-03020		2					2.13	2.23	2.34	2.45	2.72		
08-00207-03025	0.3	2.5	0.25	0.28	12°	4	45	8,100	2.66	2.78	2.91	3.05	3.39
08-00207-03030		3					3.18	3.32	3.48	3.65	4.06		
08-00207-04010		1					1.12	1.17	1.22	1.28	1.43		
08-00207-04015		1.5					1.64	1.71	1.79	1.88	2.09		
08-00207-04020	0.4	2	0.3	0.37	12°	4	45	4,600	2.16	2.26	2.36	2.48	2.76
08-00207-04025		2.5					2.68	2.80	2.93	3.08	3.42		
08-00207-04030		3					3.20	3.35	3.50	3.68	4.09		
08-00207-04035		3.5					3.72	3.89	4.08	4.28	4.75		
08-00207-04040	0.4	4	0.3	0.37	12°	4	45	4,600	4.25	4.44	4.65	4.88	5.42
08-00207-04050		5					5.29	5.53	5.79	6.08	6.75		
08-00207-04060		6					6.33	6.62	6.93	7.27	8.08		
08-00207-04080		8					8.42	8.80	9.21	9.67	10.74		
08-00207-04100	0.5	10	0.4	0.46	12°	4	45	11,000	10.50	10.98	11.49	12.07	13.40
08-00207-05010		1					1.14	1.19	1.25	1.31	1.46		
08-00207-05015		1.5					1.66	1.74	1.82	1.91	2.12		
08-00207-05020		2					2.18	2.28	2.39	2.51	2.79		
08-00207-05025	0.5	2.5	0.4	0.46	12°	4	45	3,300	2.71	2.83	2.96	3.11	3.45
08-00207-05025		2.5					2.71	2.83	2.96	3.11	3.45		

オーダー方法
How to Order

MHRH230 外径(D) × 首下長(l1)を指示してください。
When you order, indicate MHRH230 (D) × (l1).

※(γ)は参考値です。
※(γ) is reference value.

無限コーティングプレミアム 高硬度用2枚刃ロングネックエンドミル

MUGEN COATING PREMIUM 2-Flute Long Neck End Mill for Hardened Steel

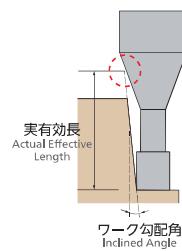

P プリハードン鋼
Prehardened Steel

M ステンレス鋼
Stainless Steel

コードNo. Code No.	(D)外径 Dia.	(ℓ ₁)首下長 Under Neck Length	(ℓ)刃長 Length of Cut	(d ₂)首下径 Neck Dia.	(γ)首角 Neck Taper Angle	(d)シャンク径 Shank Dia.	(L)全長 Overall Length	標準価格 Retail Price	ワーク勾配角に対する実有効長 Actual effective length depending on inclined angle of workpiece.				
									30°	1°	1°30'	2°	3°
08-00207-05030	0.5	3	0.4	0.46	12°	4	45	3,300	3.23	3.37	3.53	3.71	4.12
08-00207-05035		3.5					45	3,300	3.75	3.92	4.10	4.31	4.78
08-00207-05040		4					45	3,300	4.27	4.46	4.67	4.91	5.45
08-00207-05045		4.5					45	3,300	4.79	5.01	5.24	5.50	6.12
08-00207-05050		5					45	3,300	5.31	5.55	5.81	6.10	6.78
08-00207-05060		6					45	3,300	6.36	6.64	6.96	7.30	8.11
08-00207-05070		7					45	5,500	7.40	7.73	8.10	8.50	9.44
08-00207-05080		8					50	5,500	8.44	8.82	9.24	9.70	10.77
08-00207-05090		9					50	5,500	9.48	9.91	10.38	10.90	12.10
08-00207-05100		10					50	5,500	10.53	11.00	11.52	12.09	13.44
08-00207-06015	0.6	1.5	0.5	0.56	12°	4	45	3,500	1.66	1.74	1.82	1.91	2.12
08-00207-06020		2					45	3,500	2.18	2.28	2.39	2.51	2.79
08-00207-06030		3					45	3,500	3.23	3.37	3.53	3.71	4.12
08-00207-06040		4					45	3,500	4.27	4.46	4.67	4.91	5.45
08-00207-06050		5					45	3,500	5.31	5.55	5.81	6.10	6.78
08-00207-06060		6					45	3,500	6.36	6.64	6.96	7.30	8.11
08-00207-07020	0.7	2	0.55	0.66	12°	4	45	4,000	2.18	2.28	2.39	2.51	2.79
08-00207-07040		4					45	4,000	4.27	4.46	4.67	4.91	5.45
08-00207-07060		6					45	4,000	6.36	6.64	6.96	7.30	8.11
08-00207-07080		8					50	6,500	8.44	8.82	9.24	9.70	10.77
08-00207-07100		10					50	8,600	10.53	11.00	11.52	12.09	13.44
08-00207-08030		3					45	3,900	3.23	3.37	3.53	3.71	4.12
08-00207-08040	4	45	3,900	4.27	4.46	4.67	4.91	5.45					
08-00207-08050	5	45	3,900	5.31	5.55	5.81	6.10	6.78					
08-00207-08060	6	45	3,900	6.36	6.64	6.96	7.30	8.11					
08-00207-08080	8	50	3,900	8.44	8.82	9.24	9.70	10.77					
08-00207-08100	10	50	5,700	10.53	11.00	11.52	12.09	13.44					
08-00207-08120	12	50	6,500	12.61	13.18	13.80	14.49	16.10					
08-00207-10020	1	2	0.8	0.95	12°	4	50	3,500	2.21	2.31	2.42	2.54	2.82
08-00207-10030		3					50	3,500	3.25	3.40	3.56	3.74	4.15
08-00207-10040		4					50	3,500	4.29	4.49	4.70	4.93	5.48
08-00207-10050		5					50	3,500	5.34	5.58	5.84	6.13	6.81
08-00207-10060		6					50	3,500	6.38	6.67	6.98	7.33	8.14
08-00207-10070		7					50	3,500	7.42	7.76	8.12	8.53	9.47
08-00207-10080		8					50	3,500	8.47	8.85	9.27	9.73	10.80
08-00207-10090		9					50	3,500	9.51	9.94	10.41	10.92	12.14
08-00207-10100		10					50	3,500	10.55	11.03	11.55	12.12	13.47
08-00207-10120		12					50	3,500	12.64	13.21	13.83	14.52	16.13
08-00207-10140		14					50	3,500	14.72	15.39	16.11	16.91	18.79
08-00207-10160		16					60	5,700	16.81	17.57	18.40	19.31	21.45
08-00207-10180		18					60	5,700	18.89	19.74	20.68	21.71	24.11
08-00207-10200		20					60	5,700	20.98	21.92	22.96	24.10	26.78
08-00207-10220	22	60	6,600	23.07	24.10	25.24	26.50	Free					
08-00207-12060	1.2	6	1	1.15	12°	4	50	3,700	6.38	6.67	6.98	7.33	8.14
08-00207-12080		8					50	3,700	8.47	8.85	9.27	9.73	10.80
08-00207-12100		10					50	3,700	10.55	11.03	11.55	12.12	13.47
08-00207-12120		12					50	3,700	12.64	13.21	13.83	14.52	16.13
08-00207-12160		16					60	5,900	16.81	17.57	18.40	19.31	21.45
08-00207-14060		1.4					6	1.1	1.35	12°	4	50	3,800
08-00207-14120	12		50	3,800	12.64	13.21	13.83					14.52	16.13

S チタン合金
耐熱合金
Titanium Alloy
Heat Resistant Alloy

H ハードコート
高硬度鋼
Hardened Steel

~55 HRC

~65 HRC



MHRH230

無限コーティングプレミアム 高硬度用2枚刃ロングネックエンドミル

MUGEN COATING PREMIUM 2-Flute Long Neck End Mill for Hardened Steel

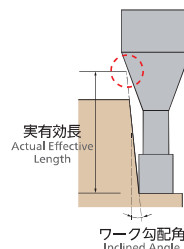

単位【寸法：mm / 価格：円】
Unit [Size : mm / Retail Price : JPY]

コードNo. Code No.	(D)外径 Dia.	(ℓ1)首下長 Under Neck Length	(ℓ)刃長 Length of Cut	(d2)首下径 Neck Dia.	(γ)首角 Neck Taper Angle	(d)シャンク径 Shank Dia.	(L)全長 Overall Length	標準価格 Retail Price	ワーク勾配角に対する実有効長 Actual effective length depending on inclined angle of workpiece.									
									30°	1°	1°30'	2°	3°					
08-00207-15040	1.5	4	1.2	1.45	12°	4	50	3,700	4.29	4.49	4.70	4.93	5.48					
08-00207-15060		6					50	3,700	6.38	6.67	6.98	7.33	8.14					
08-00207-15080		8					50	3,700	8.47	8.85	9.27	9.73	10.80					
08-00207-15100		10					50	3,700	10.55	11.03	11.55	12.12	13.47					
08-00207-15120		12					50	3,700	12.64	13.21	13.83	14.52	16.13					
08-00207-15140		14					60	3,800	14.72	15.39	16.11	16.91	18.79					
08-00207-15160		16					60	3,800	16.81	17.57	18.40	19.31	21.45					
08-00207-15180		18					60	3,800	18.89	19.74	20.68	21.71	24.11					
08-00207-15200		20					60	3,800	20.98	21.92	22.96	24.10	Free					
08-00207-15250		25					70	5,700	26.20	27.37	28.67	30.09	Free					
08-00207-15300		30					70	5,700	31.41	32.82	34.37	36.08	Free					
08-00207-15350		35					80	6,500	36.62	38.27	40.08	Free	Free					
08-00207-16060	1.6	6	1.3	1.55	12°	4	50	3,800	6.38	6.67	6.98	7.33	8.14					
08-00207-16080		8					50	3,800	8.47	8.85	9.27	9.73	10.80					
08-00207-18060	1.8	6	1.4	1.75	12°	4	50	3,800	6.38	6.67	6.98	7.33	8.14					
08-00207-18080		8					50	3,800	8.47	8.85	9.27	9.73	10.80					
08-00207-18100		10					50	3,800	10.55	11.03	11.55	12.12	13.47					
08-00207-18120		12					50	3,800	12.64	13.21	13.83	14.52	16.13					
08-00207-18140		14					50	3,800	14.72	15.39	16.11	16.91	18.79					
08-00207-18160		16					60	3,800	16.81	17.57	18.40	19.31	21.45					
08-00207-18180		18					60	3,800	18.89	19.74	20.68	21.71	24.11					
08-00207-20040		2					4	1.6	1.94	12°	4	50	3,700	4.32	4.51	4.73	4.96	5.51
08-00207-20060	6		50	3,700	6.40	6.69	7.01					7.36	8.17					
08-00207-20080	8		50	3,700	8.49	8.87	9.29					9.75	10.84					
08-00207-20100	10		50	3,700	10.58	11.05	11.57					12.15	13.50					
08-00207-20120	12		50	3,700	12.66	13.23	13.86					14.55	16.16					
08-00207-20140	14		60	3,700	14.75	15.41	16.14					16.94	18.82					
08-00207-20160	16		60	3,700	16.83	17.59	18.42					19.34	Free					
08-00207-20180	18		60	3,700	18.92	19.77	20.71					21.73	Free					
08-00207-20200	20		60	3,700	21.01	21.95	22.99					24.13	Free					
08-00207-20250	25		70	3,700	26.22	27.40	28.69					Free	Free					
08-00207-20300	30		70	4,600	31.43	32.85	34.40					Free	Free					
08-00207-20350	35		80	5,500	36.65	38.30	Free					Free	Free					
08-00207-20400	40		90	6,900	41.86	43.75	Free					Free	Free					
08-00207-20500	50		100	8,300	52.29	54.64	Free					Free	Free					
08-00207-25080	2.5		8	2	2.4	12°	4					50	3,900	8.59	8.98	9.40	9.87	10.96
08-00207-25120			12									50	3,900	12.76	13.33	13.97	14.66	Free
08-00207-25160			16									60	3,900	16.93	17.69	18.53	19.45	Free
08-00207-25200			20									60	3,900	21.10	22.05	23.10	Free	Free
08-00207-25300		30	70					4,200	31.53	32.95	Free	Free	Free					
08-00207-25400		40	90					5,900	41.96	43.85	Free	Free	Free					
08-00207-25500		50	100					7,300	52.39	54.75	Free	Free	Free					
08-00207-30080		3	8					4.5	2.85	12°	6	50	5,000	8.71	9.10	9.53	10.01	11.12
08-00207-30120	12		50	5,000	12.88	13.46	14.10					14.80	16.44					
08-00207-30160	16		60	5,000	17.05	17.82	18.67					19.59	21.77					
08-00207-30200	20		60	5,000	21.23	22.18	23.23					24.39	27.09					
08-00207-30250	25		70	5,000	26.44	27.63	28.94					30.38	Free					
08-00207-30300	30		70	6,000	31.66	33.08	34.64					36.37	Free					

オーダー方法
How to Order

MHRH230 外径(D)×首下長(ℓ1)を指示してください。
When you order, indicate MHRH230 (D)×(ℓ1).

※(γ)は参考値です。
※(γ) is reference value.

切削条件参考表

Recommended Milling Conditions

被削材 Work Material		炭素鋼・調質鋼 Carbon Steels・Prehardened Steels S50C・NAK55・NAK80・HPM1 (~43HRC)				高硬度鋼 Hardened Steels HPM38・STAVAX・SKD61 (~55HRC)				高硬度鋼 Hardened Steels SKD11・PD613 (~62HRC)				ハイス High Speed Steels SKH (~65HRC)			
		回転数 Spindle Speed	送り速度 Feed	切込み量 Depth of Cut		回転数 Spindle Speed	送り速度 Feed	切込み量 Depth of Cut		回転数 Spindle Speed	送り速度 Feed	切込み量 Depth of Cut		回転数 Spindle Speed	送り速度 Feed	切込み量 Depth of Cut	
外径 Dia.	首下長 Under Neck Length	min ⁻¹	mm/min	ap mm	ae mm	min ⁻¹	mm/min	ap mm	ae mm	min ⁻¹	mm/min	ap mm	ae mm	min ⁻¹	mm/min	ap mm	ae mm
		0.1	0.3	40,000	150	0.005	0.06	40,000	120	0.003	0.05	40,000	100	0.002	0.04	40,000	70
0.5	40,000		100	0.005	0.06	40,000	80	0.003	0.05	40,000	60	0.002	0.04	40,000	50	0.002	0.03
0.75	40,000		80	0.003	0.06	40,000	70	0.002	0.05	40,000	50	0.001	0.04	40,000	30	0.001	0.03
1	40,000		60	0.002	0.06	40,000	50	0.001	0.05	40,000	40	0.001	0.04	40,000	20	0.001	0.03
0.15	0.3	40,000	180	0.005	0.09	40,000	150	0.003	0.07	40,000	120	0.002	0.06	40,000	100	0.002	0.04
	0.5	40,000	150	0.005	0.09	40,000	120	0.003	0.07	40,000	100	0.002	0.06	40,000	80	0.002	0.04
	0.75	40,000	120	0.003	0.09	40,000	100	0.002	0.07	40,000	80	0.001	0.06	40,000	60	0.001	0.04
	1	40,000	100	0.002	0.09	40,000	80	0.001	0.07	40,000	60	0.001	0.06	40,000	40	0.001	0.04
0.2	0.5	30,000	240	0.005	0.12	30,000	200	0.003	0.1	30,000	160	0.003	0.08	30,000	120	0.003	0.06
	0.75	30,000	200	0.005	0.12	30,000	180	0.003	0.1	30,000	140	0.003	0.08	30,000	100	0.003	0.06
	1	30,000	180	0.005	0.12	30,000	150	0.003	0.1	30,000	120	0.003	0.08	30,000	80	0.003	0.06
	1.5	30,000	120	0.003	0.12	30,000	100	0.002	0.1	30,000	80	0.002	0.08	30,000	60	0.002	0.06
0.2	2	30,000	80	0.003	0.12	30,000	50	0.002	0.1	30,000	40	0.002	0.08	30,000	30	0.002	0.06
	2.5	30,000	60	0.002	0.12	30,000	50	0.001	0.1	25,000	40	0.001	0.08	25,000	30	0.001	0.06
	3	30,000	40	0.002	0.12	25,000	40	0.001	0.1	25,000	30	0.001	0.08	22,000	20	0.001	0.06
	1	30,000	350	0.007	0.18	30,000	300	0.003	0.15	30,000	250	0.003	0.12	30,000	200	0.003	0.09
0.3	1.5	30,000	260	0.007	0.18	30,000	200	0.003	0.15	30,000	160	0.003	0.12	30,000	120	0.003	0.09
	2	30,000	180	0.005	0.18	30,000	150	0.003	0.15	30,000	120	0.003	0.12	25,000	100	0.003	0.09
	2.5	30,000	150	0.004	0.18	25,000	100	0.002	0.15	25,000	80	0.002	0.12	20,000	60	0.002	0.09
	3	30,000	70	0.004	0.18	25,000	50	0.002	0.15	25,000	40	0.002	0.12	20,000	30	0.002	0.09
0.4	1	30,000	450	0.01	0.24	30,000	400	0.005	0.2	30,000	350	0.005	0.16	25,000	300	0.005	0.12
	1.5	30,000	400	0.01	0.24	30,000	360	0.005	0.2	30,000	330	0.005	0.16	25,000	250	0.005	0.12
	2	30,000	360	0.01	0.24	30,000	320	0.005	0.2	25,000	280	0.005	0.16	25,000	220	0.005	0.12
	2.5	30,000	340	0.008	0.24	25,000	280	0.005	0.2	25,000	250	0.004	0.16	20,000	200	0.004	0.12
	3	30,000	320	0.008	0.24	25,000	260	0.004	0.2	20,000	220	0.003	0.16	18,000	180	0.003	0.12
	3.5	30,000	280	0.007	0.24	25,000	220	0.004	0.2	20,000	180	0.003	0.16	18,000	150	0.002	0.12
	4	30,000	250	0.006	0.24	25,000	200	0.003	0.2	20,000	160	0.002	0.16	18,000	120	0.002	0.12
	5	25,000	250	0.005	0.24	22,000	180	0.003	0.2	20,000	150	0.002	0.16	18,000	90	0.002	0.12
	6	25,000	200	0.004	0.24	22,000	150	0.002	0.2	18,000	130	0.002	0.16	16,000	70	0.001	0.12
	8	20,000	150	0.002	0.24	16,000	120	0.001	0.2	14,000	90	0.001	0.16	12,000	40	0.001	0.12
0.5	10	16,000	100	0.002	0.24	13,000	80	0.001	0.2	12,000	50	0.001	0.16	10,000	20	0.001	0.12
	1	30,000	550	0.02	0.3	25,000	500	0.01	0.25	23,000	450	0.007	0.2	20,000	400	0.005	0.15
	1.5	30,000	520	0.02	0.3	25,000	450	0.01	0.25	23,000	400	0.007	0.2	20,000	360	0.005	0.15
	2	30,000	500	0.02	0.3	25,000	420	0.01	0.25	23,000	380	0.007	0.2	20,000	320	0.005	0.15
	2.5	30,000	480	0.015	0.3	25,000	400	0.008	0.25	23,000	360	0.006	0.2	20,000	300	0.004	0.15
	3	30,000	420	0.015	0.3	25,000	350	0.007	0.25	23,000	320	0.005	0.2	20,000	280	0.003	0.15
	3.5	25,000	400	0.012	0.3	25,000	320	0.006	0.25	23,000	280	0.003	0.2	20,000	240	0.003	0.15
	4	25,000	380	0.01	0.3	25,000	280	0.005	0.25	23,000	240	0.003	0.2	20,000	200	0.002	0.15
	4.5	25,000	350	0.008	0.3	25,000	230	0.004	0.25	20,000	200	0.003	0.2	18,000	160	0.002	0.15
	5	25,000	320	0.007	0.3	20,000	200	0.003	0.25	18,000	150	0.003	0.2	16,000	100	0.002	0.15
0.6	6	25,000	300	0.005	0.3	20,000	200	0.003	0.25	18,000	150	0.002	0.2	16,000	100	0.002	0.15
	7	20,000	250	0.005	0.3	16,000	180	0.003	0.25	14,000	140	0.002	0.2	14,000	80	0.002	0.15
	8	20,000	200	0.005	0.3	16,000	160	0.002	0.25	14,000	130	0.002	0.2	12,000	60	0.001	0.15
	9	20,000	200	0.003	0.3	16,000	150	0.002	0.25	14,000	120	0.001	0.2	12,000	50	0.001	0.15
	10	16,000	170	0.003	0.3	13,000	130	0.002	0.25	12,000	110	0.001	0.2	10,000	40	0.001	0.15
	1.5	30,000	650	0.02	0.35	25,000	550	0.01	0.3	23,000	450	0.007	0.25	20,000	400	0.005	0.18
	2	30,000	550	0.02	0.35	25,000	500	0.01	0.3	23,000	400	0.007	0.25	20,000	350	0.005	0.18
	3	30,000	500	0.015	0.35	25,000	450	0.007	0.3	23,000	350	0.005	0.25	20,000	300	0.003	0.18
	4	25,000	450	0.01	0.35	25,000	400	0.005	0.3	23,000	300	0.003	0.25	20,000	250	0.002	0.18

P プリハードン鋼
Prehardened Steel

M ステンレス鋼
Stainless Steel

S チタン合金
耐熱合金
Titanium Alloy
Heat Resistant Alloy

H 高硬度鋼
Hardened Steel

~55 HRC

~65 HRC



MHRH230

切削条件参考表

Recommended Milling Conditions

被削材 Work Material		炭素鋼・調質鋼 Carbon Steels・Prehardened Steels S50C・NAK55・NAK80・HPM1 (~43HRC)				高硬度鋼 Hardened Steels HPM38・STAVAX・SKD61 (~55HRC)				高硬度鋼 Hardened Steels SKD11・PD613 (~62HRC)				ハイス High Speed Steels SKH (~65HRC)			
外径 Dia.	首下長 Under Neck Length	回転数 Spindle Speed	送り速度 Feed	切込み量 Depth of Cut		回転数 Spindle Speed	送り速度 Feed	切込み量 Depth of Cut		回転数 Spindle Speed	送り速度 Feed	切込み量 Depth of Cut		回転数 Spindle Speed	送り速度 Feed	切込み量 Depth of Cut	
		min ⁻¹	mm/min	ap mm	ae mm	min ⁻¹	mm/min	ap mm	ae mm	min ⁻¹	mm/min	ap mm	ae mm	min ⁻¹	mm/min	ap mm	ae mm
0.6	5	25,000	400	0.007	0.35	20,000	350	0.003	0.3	18,000	250	0.003	0.25	16,000	200	0.002	0.18
	6	25,000	350	0.005	0.35	20,000	300	0.002	0.3	18,000	200	0.002	0.25	16,000	150	0.001	0.18
0.7	2	30,000	750	0.04	0.4	25,000	600	0.03	0.35	23,000	450	0.02	0.28	20,000	400	0.012	0.21
	4	25,000	690	0.03	0.4	25,000	560	0.02	0.35	23,000	400	0.015	0.28	20,000	320	0.007	0.21
	6	25,000	550	0.02	0.4	20,000	410	0.015	0.35	18,000	300	0.012	0.28	16,000	240	0.007	0.21
	8	20,000	430	0.012	0.4	16,000	330	0.01	0.35	14,000	230	0.007	0.28	12,000	180	0.005	0.21
0.8	10	16,000	300	0.008	0.4	13,000	200	0.005	0.35	12,000	180	0.003	0.28	10,000	120	0.002	0.21
	3	25,000	850	0.04	0.45	25,000	780	0.03	0.4	23,000	650	0.02	0.32	20,000	550	0.012	0.24
	4	25,000	800	0.03	0.45	25,000	700	0.025	0.4	23,000	600	0.015	0.32	20,000	500	0.007	0.24
	5	25,000	700	0.03	0.45	23,000	630	0.02	0.4	20,000	530	0.012	0.32	18,000	450	0.006	0.24
	6	20,000	620	0.025	0.45	20,000	550	0.02	0.4	18,000	450	0.01	0.32	16,000	350	0.005	0.24
	8	16,000	500	0.015	0.45	16,000	400	0.007	0.4	14,000	300	0.005	0.32	12,000	200	0.003	0.24
1	10	16,000	400	0.012	0.45	16,000	350	0.007	0.4	12,000	180	0.005	0.32	10,000	150	0.003	0.24
	12	16,000	300	0.007	0.45	13,000	220	0.005	0.4	12,000	120	0.003	0.32	10,000	120	0.002	0.24
	2	25,000	1,200	0.07	0.6	23,000	1,000	0.06	0.5	18,000	900	0.05	0.4	14,000	600	0.035	0.3
	3	25,000	1,200	0.06	0.6	23,000	1,000	0.05	0.5	18,000	900	0.04	0.4	14,000	600	0.03	0.3
	4	25,000	1,000	0.05	0.6	23,000	900	0.04	0.5	18,000	800	0.03	0.4	14,000	500	0.02	0.3
	5	22,000	1,000	0.04	0.6	20,000	800	0.03	0.5	16,000	700	0.02	0.4	12,000	450	0.012	0.3
	6	20,000	900	0.03	0.6	18,000	700	0.02	0.5	14,000	600	0.01	0.4	10,000	400	0.007	0.3
	7	20,000	900	0.03	0.6	18,000	650	0.02	0.5	14,000	550	0.01	0.4	10,000	370	0.006	0.3
	8	18,000	800	0.03	0.6	16,000	600	0.02	0.5	12,000	500	0.01	0.4	8,000	340	0.005	0.3
	9	18,000	700	0.02	0.6	16,000	550	0.015	0.5	12,000	450	0.007	0.4	8,000	300	0.005	0.3
1.2	10	16,000	600	0.02	0.6	14,000	500	0.01	0.5	10,000	400	0.007	0.4	6,000	250	0.005	0.3
	12	16,000	500	0.02	0.6	13,000	400	0.01	0.5	10,000	300	0.005	0.4	6,000	180	0.004	0.3
	14	16,000	450	0.015	0.6	13,000	360	0.008	0.5	10,000	280	0.005	0.4	5,500	160	0.004	0.3
	16	14,000	400	0.012	0.6	12,000	320	0.006	0.5	9,000	250	0.004	0.4	5,500	150	0.003	0.3
	18	14,000	300	0.01	0.6	12,000	240	0.006	0.5	8,000	200	0.004	0.4	5,000	120	0.002	0.3
	20	12,000	200	0.007	0.6	10,000	160	0.005	0.5	7,000	130	0.003	0.4	4,500	90	0.001	0.3
	22	12,000	180	0.005	0.6	10,000	150	0.003	0.5	6,000	100	0.002	0.4	4,200	60	0.001	0.3
	6	20,000	900	0.04	0.7	18,000	700	0.03	0.6	14,000	600	0.02	0.5	10,000	400	0.01	0.4
1.4	8	18,000	800	0.04	0.7	16,000	600	0.02	0.6	12,000	500	0.01	0.5	8,000	340	0.007	0.4
	10	16,000	600	0.03	0.7	12,000	500	0.02	0.6	10,000	430	0.01	0.5	8,000	300	0.005	0.4
	12	14,000	600	0.02	0.7	10,000	500	0.01	0.6	9,000	400	0.007	0.5	7,000	250	0.005	0.4
	16	12,000	400	0.018	0.7	9,000	300	0.01	0.6	8,000	260	0.005	0.5	6,000	180	0.003	0.4
1.5	6	22,000	1,000	0.06	0.8	20,000	800	0.04	0.7	18,000	700	0.03	0.56	12,000	450	0.02	0.42
	12	16,000	700	0.03	0.8	13,000	500	0.01	0.7	11,000	400	0.007	0.56	8,000	280	0.005	0.42
	4	23,000	1,200	0.07	0.9	20,000	900	0.05	0.75	18,000	800	0.04	0.6	14,000	600	0.03	0.45
	6	23,000	1,000	0.06	0.9	20,000	800	0.04	0.75	18,000	700	0.03	0.6	14,000	500	0.02	0.45
	8	20,000	900	0.06	0.9	18,000	600	0.03	0.75	14,000	600	0.03	0.6	10,000	380	0.01	0.45
	10	20,000	800	0.04	0.9	16,000	500	0.03	0.75	14,000	500	0.02	0.6	10,000	350	0.01	0.45
	12	16,000	700	0.04	0.9	14,000	500	0.02	0.75	12,000	430	0.02	0.6	8,000	310	0.007	0.45
	14	14,000	600	0.03	0.9	12,000	400	0.02	0.75	10,000	380	0.01	0.6	7,500	250	0.007	0.45
	16	12,000	500	0.02	0.9	10,000	360	0.01	0.75	9,000	300	0.007	0.6	6,800	200	0.005	0.45
	18	10,000	400	0.02	0.9	9,000	330	0.008	0.75	8,000	260	0.005	0.6	6,000	170	0.004	0.45
1.6	20	9,000	320	0.014	0.9	8,000	280	0.005	0.75	7,000	200	0.004	0.6	5,500	150	0.003	0.45
	25	8,000	250	0.01	0.9	7,000	200	0.004	0.75	6,000	150	0.003	0.6	4,500	100	0.002	0.45
	30	7,000	200	0.005	0.9	6,000	150	0.003	0.75	5,000	110	0.002	0.6	4,000	80	0.002	0.45
	35	6,000	150	0.003	0.9	5,000	110	0.002	0.75	4,500	90	0.002	0.6	3,500	60	0.002	0.45
	6	22,000	1,000	0.06	0.96	19,000	850	0.04	0.8	17,000	750	0.03	0.64	13,000	600	0.025	0.48
	8	20,000	900	0.06	0.96	17,000	750	0.03	0.8	14,000	600	0.03	0.64	10,000	430	0.015	0.48

プリハードン鋼
Prehardened Steel **P**
 ステンレス鋼
Stainless Steel **M**

チタン合金
耐熱合金
Titanium Alloy
Heat Resistant Alloy **S**
 高硬度鋼
Hardened Steel **H**

Coating
コート
Long neck
ロングネック
Long Neck
ロングネック
スクエア
スクエア

切削条件参考表

Recommended Milling Conditions

被削材 Work Material		炭素鋼・調質鋼 Carbon Steels・Prehardened Steels S50C・NAK55・NAK80・HPM1 (~43HRC)				高硬度鋼 Hardened Steels HPM38・STAVAX・SKD61 (~55HRC)				高硬度鋼 Hardened Steels SKD11・PD613 (~62HRC)				ハイス High Speed Steels SKH (~65HRC)			
外径 Dia.	首下長 Under Neck Length	回転数 Spindle Speed	送り速度 Feed	切込み量 Depth of Cut		回転数 Spindle Speed	送り速度 Feed	切込み量 Depth of Cut		回転数 Spindle Speed	送り速度 Feed	切込み量 Depth of Cut		回転数 Spindle Speed	送り速度 Feed	切込み量 Depth of Cut	
		min ⁻¹	mm/min	ap mm	ae mm	min ⁻¹	mm/min	ap mm	ae mm	min ⁻¹	mm/min	ap mm	ae mm	min ⁻¹	mm/min	ap mm	ae mm
1.8	6	20,000	1,000	0.07	1	18,000	900	0.05	0.9	15,000	750	0.04	0.7	12,000	600	0.03	0.5
	8	18,000	900	0.06	1	16,000	800	0.04	0.9	12,000	600	0.03	0.7	9,500	500	0.02	0.5
	10	16,000	800	0.06	1	14,000	700	0.04	0.9	12,000	500	0.03	0.7	9,500	450	0.02	0.5
	12	14,000	700	0.05	1	12,000	600	0.03	0.9	10,000	500	0.02	0.7	8,200	400	0.01	0.5
	14	14,000	700	0.05	1	12,000	600	0.03	0.9	10,000	430	0.02	0.7	8,200	360	0.01	0.5
	16	12,000	600	0.04	1	10,000	500	0.02	0.9	9,200	400	0.01	0.7	7,500	340	0.007	0.5
	18	10,000	500	0.04	1	9,200	410	0.02	0.9	8,500	370	0.01	0.7	6,000	320	0.007	0.5
2	4	20,000	1,200	0.1	1.2	18,000	1,000	0.08	1	15,000	800	0.06	0.8	12,000	600	0.04	0.6
	6	20,000	1,000	0.08	1.2	18,000	900	0.06	1	15,000	750	0.05	0.8	12,000	600	0.03	0.6
	8	18,000	900	0.07	1.2	16,000	800	0.05	1	12,000	600	0.04	0.8	9,500	500	0.02	0.6
	10	16,000	800	0.06	1.2	14,000	700	0.05	1	12,000	500	0.04	0.8	9,500	450	0.02	0.6
	12	14,000	700	0.05	1.2	12,000	600	0.04	1	10,000	500	0.03	0.8	8,200	400	0.01	0.6
	14	14,000	700	0.04	1.2	12,000	600	0.03	1	10,000	430	0.02	0.8	8,200	360	0.007	0.6
	16	12,000	600	0.04	1.2	10,000	500	0.03	1	9,200	400	0.02	0.8	7,500	340	0.007	0.6
	18	10,000	500	0.03	1.2	9,200	410	0.02	1	8,500	370	0.01	0.8	6,000	320	0.005	0.6
	20	10,000	400	0.03	1.2	9,200	380	0.02	1	8,500	340	0.01	0.8	6,000	260	0.005	0.6
	25	9,000	350	0.02	1.2	8,500	330	0.015	1	8,000	300	0.008	0.8	5,000	180	0.004	0.6
	30	8,000	300	0.015	1.2	7,500	280	0.01	1	7,000	250	0.006	0.8	4,500	150	0.004	0.6
	35	7,000	250	0.012	1.2	6,500	230	0.008	1	6,000	200	0.005	0.8	4,000	120	0.003	0.6
2.5	8	16,000	1,000	0.08	1.5	14,000	800	0.07	1.25	10,000	700	0.05	1	8,000	500	0.03	0.75
	12	14,000	800	0.07	1.5	12,000	700	0.06	1.25	9,600	600	0.04	1	7,500	480	0.02	0.75
	16	12,000	700	0.06	1.5	10,000	600	0.05	1.25	8,500	500	0.02	1	7,000	400	0.01	0.75
	20	10,000	600	0.06	1.5	8,200	500	0.05	1.25	7,500	500	0.02	1	5,000	400	0.01	0.75
	30	8,000	400	0.03	1.5	7,000	300	0.025	1.25	6,000	250	0.015	1	4,000	150	0.008	0.75
	40	6,000	250	0.015	1.5	5,500	200	0.012	1.25	5,000	180	0.01	1	3,500	110	0.005	0.75
	50	5,000	150	0.01	1.5	4,500	120	0.008	1.25	4,000	100	0.005	1	3,000	70	0.004	0.75
3	8	16,000	1,000	0.15	1.8	14,000	900	0.1	1.5	10,000	800	0.07	1.2	8,000	600	0.05	0.9
	12	14,000	900	0.1	1.8	12,000	800	0.08	1.5	9,200	700	0.06	1.2	7,200	500	0.04	0.9
	16	12,000	800	0.08	1.8	10,000	700	0.07	1.5	8,500	600	0.05	1.2	6,500	400	0.03	0.9
	20	10,000	800	0.08	1.8	9,000	700	0.07	1.5	7,800	600	0.04	1.2	5,800	400	0.02	0.9
	25	9,000	700	0.07	1.8	8,200	600	0.06	1.5	7,000	500	0.03	1.2	5,000	360	0.01	0.9
30	8,000	700	0.05	1.8	7,000	600	0.03	1.5	6,500	500	0.02	1.2	4,500	330	0.007	0.9	

備考 Notes

- ※1 本切削条件は参考値です。実際の加工形状および使用機械等にて切削条件を調整してください。
- ※2 切込み量の、apは軸方向の切込み深さ、aeは半径方向の切込み深さを示します。
- ※3 高硬度鋼を切削加工する場合は、オイルミストクーラントをお奨めします。
- ※4 Z切込み時のアプローチ方法として、ヘリカル（螺旋）及びランプ（傾斜）での切削加工をお奨めします。
- ※5 L(首下長)/D(外径)が8倍を超える場合は立ち壁付近の送り速度を50%以下、切込み量：aeを30%以下に調整してください。
- ※6 溝切削は、切削条件参考表を参考に切込み量：ap及び送り速度を50%以下に設定し、往復切削をお奨めします。
- ※7 びびりが発生する場合は、回転数と送り速度を同じ割合で下げてください。また、主軸回転数が足りない場合も同様に同じ割合で下げてください。
- ※8 L(首下長)/D(外径)が5倍以上の場合、首下長の短い工具でのガイド溝加工をお奨めします。
- ※9 φ0.5未満あるいはL(首下長)/D(外径)が15倍以上の場合、加工形状・使用機械等により、大幅な条件調整を必要とする場合があります。
- ※1 These recommended cutting conditions indicate just reference. It should be adjusted according to milling shape and machine type.
- ※2 ap:Axial Depth of Cut, ae:Radial Depth of Cut.
- ※3 Recommend to use oil mist coolant for machining hardened steel.
- ※4 Recommend to apply herical or ramping for approaching into axial direction.
- ※5 Adjust feed rate 50% lower and cutting depth(ae) 30% lower for milling deep wall area. When L/D exceeds 8 for stable milling.
- ※6 For slotting, recommend reciprocating milling by adjusting feed & ap in below 50% of recommended milling condition.
- ※7 Reduce both spindle speed and feed at same rate for chattering and also for insufficient spindle speed of a machine.
- ※8 Recommend guide slotting process with short neck tool before milling with L/D 5 time or longer neck tool.
- ※9 Major adjustment of milling conditions appropriately on milling profile, machine tool and etc. required for the tools smaller than Dia. 0.5mm, or L/D 15 times longer.

P プリハードン鋼
Prehardened Steel

M ステンレス鋼
Stainless Steel

S チタン合金
耐熱合金
Titanium Alloy
Heat Resistant Alloy

H 高硬度鋼
Hardened Steel
~55 HRC
~65 HRC

ロングネック
Square
ソリッド
コーティング

MHRH430

サイズ
Size $\phi 1 \sim \phi 6$



無限コーティングプレミアム 高硬度用4枚刃ロングネックエンドミル

MUGEN COATING PREMIUM 4-Flute Long Neck End Mill for Hardened Steel

調質鋼・高硬度鋼（～65HRC）対応の 4枚刃ロングネックスクエアエンドミル。L/Dは最大10倍

4-flute long neck square end mill for prehardened steels and hardened steels up to 65HRC
Maximum L/D=10

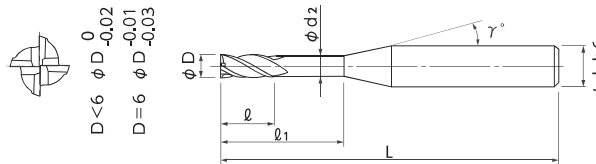
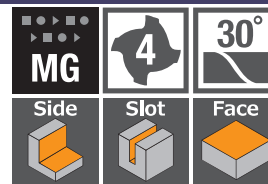

- 無限コーティングプレミアムの採用により、高硬度鋼の加工に長寿命！加工精度も向上！
- 微細加工時の工具剛性がアップ！
- 全55サイズ！
- MUGEN COATING PREMIUM to improve accuracy and tool life on machining hardened steels!
- Improve tool rigidity for precision machining!
- Total 55 sizes!

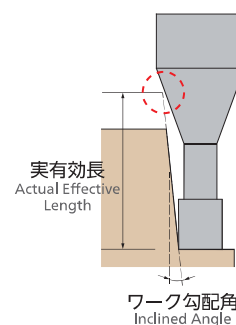

★再研磨可能(シャンク長15mm以上のもの。詳細はお問い合わせください。)

単位 [寸法 : mm / 価格 : 円]
Unit [Size : mm / Retail Price : JPY]

コードNo. Code No.	(D)外径 Dia.	(d1)首下長 Under Neck Length	(L)刃長 Length of Cut	(d2)首下径 Neck Dia.	(γ)首角 Neck Taper Angle	(d)シャンク径 Shank Dia.	(L)全長 Overall Length	標準価格 Retail Price	ワーク勾配角に対する実有効長 Actual effective length depending on inclined angle of workpiece.				
									30°	1°	1°30'	2°	3°
08-00217-01004	1	4	0.8	0.95	12°	4	50	4,950	4.29	4.49	4.70	4.93	5.47
08-00217-01006		6							6.38	6.66	6.98	7.32	8.12
08-00217-01008		8							8.47	8.84	9.26	9.71	10.77
08-00217-01010		10							10.55	11.02	11.54	12.11	13.43
08-00217-01206	1.2	6	1	1.15	12°	4	50	4,950	6.38	6.66	6.98	7.32	8.12
08-00217-01208		8							8.47	8.84	9.26	9.71	10.77
08-00217-01210		10							10.55	11.02	11.54	12.11	13.43
08-00217-01212		12							12.64	13.20	13.82	14.50	16.08
08-00217-01506	1.5	6	1.2	1.45	12°	4	50	4,950	6.38	6.66	6.98	7.32	8.12
08-00217-01508		8							8.47	8.84	9.26	9.71	10.77
08-00217-01510		10							10.55	11.02	11.54	12.11	13.43
08-00217-01512		12							12.64	13.20	13.82	14.50	16.08
08-00217-01514		14							14.72	15.38	16.10	16.89	18.74
08-00217-01516		16							16.81	17.56	18.38	19.29	21.39
08-00217-01806	1.8	6	1.4	1.74	12°	4	50	4,950	6.40	6.69	7.00	7.35	8.15
08-00217-01808		8							8.49	8.87	9.29	9.74	10.81
08-00217-01810		10							10.58	11.05	11.57	12.13	13.46
08-00217-01812		12							12.66	13.23	13.85	14.53	16.11
08-00217-01814		14							14.75	15.41	16.13	16.92	18.77
08-00217-01816		16							16.83	17.59	18.41	19.31	Free
08-00217-01818		18							18.92	19.76	20.69	21.71	Free

オーダー方法
How to Order

MHRH430 外径(D)×首下長(d1)を指示してください。
When you order, indicate MHRH430 (D)×(d1).

※(γ)は参考値です。
※(γ) is reference value.

無限コーティングプレミアム 高硬度用4枚刃ロングネックエンドミル

MUGEN COATING PREMIUM 4-Flute Long Neck End Mill for Hardened Steel

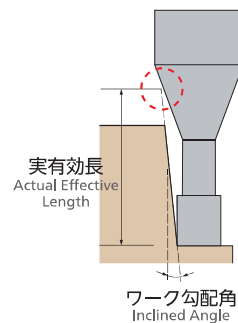

コードNo. Code No.	(D)外径 Dia.	(d1)首下長 Under Neck Length	(d)刃長 Length of Cut	(d2)首下径 Neck Dia.	(γ)首角 Neck Taper Angle	(d)シャンク径 Shank Dia.	(L)全長 Overall Length	標準価格 Retail Price	ワーク勾配角に対する実有効長 Actual effective length depending on inclined angle of workpiece.				
									30°	1°	1°30'	2°	3°
08-00217-02006	2	6	1.6	1.94	12°	4	50	4,950	6.40	6.69	7.00	7.35	8.15
08-00217-02008		8					50	4,950	8.49	8.87	9.29	9.74	10.81
08-00217-02010		10					50	4,950	10.58	11.05	11.57	12.13	13.46
08-00217-02012		12					50	4,950	12.66	13.23	13.85	14.53	16.11
08-00217-02014		14					60	4,950	14.75	15.41	16.13	16.92	18.77
08-00217-02016		16					60	4,950	16.83	17.59	18.41	19.31	Free
08-00217-02018		18					60	4,950	18.92	19.76	20.69	21.71	Free
08-00217-02020		20					60	4,950	21.00	21.94	22.97	24.10	Free
08-00217-02508	2.5	8	2	2.4	12°	4	50	4,950	8.59	8.97	9.39	9.85	10.93
08-00217-02512		12					50	4,950	12.76	13.33	13.95	14.64	Free
08-00217-02516		16					60	4,950	16.93	17.69	18.52	19.43	Free
08-00217-02520		20					60	4,950	21.10	22.05	23.08	Free	Free
08-00217-02525		25					70	5,300	26.32	27.49	Free	Free	Free
★08-00217-03008	3	8	4.5	2.85	12°	6	50	7,000	8.71	9.10	9.53	9.99	11.09
★08-00217-03012		12					50	7,000	12.88	13.46	14.09	14.78	16.40
★08-00217-03016		16					60	7,000	17.05	17.82	18.65	19.57	21.70
★08-00217-03020		20					60	7,000	21.22	22.17	23.21	24.35	27.01
★08-00217-03025		25					70	7,400	26.44	27.62	28.92	30.34	Free
★08-00217-03030		30					70	8,000	31.65	33.07	34.62	36.32	Free
★08-00217-04012	4	12	6	3.8	12°	6	50	7,300	13.00	13.59	14.22	14.92	16.55
★08-00217-04016		16					60	7,300	17.18	17.94	18.78	19.71	Free
★08-00217-04020		20					60	7,300	21.35	22.30	23.35	24.49	Free
★08-00217-04025		25					70	7,700	26.56	27.75	29.05	Free	Free
★08-00217-04030		30					70	8,500	31.78	33.20	34.75	Free	Free
★08-00217-04035		35					80	9,200	36.99	38.64	Free	Free	Free
★08-00217-04040		40					90	9,700	42.20	44.09	Free	Free	Free
★08-00217-05016		5					16	7.5	4.8	12°	6	60	9,200
★08-00217-05025	25		70	9,600	26.56	27.75	Free					Free	Free
★08-00217-05035	35		80	10,000	36.99	Free	Free					Free	Free
★08-00217-05050	50		110	14,000	52.63	Free	Free					Free	Free
★08-00217-06020	6	20	9	5.8	-	6	80	9,200	Free	Free	Free	Free	Free
★08-00217-06030		30					90	9,600	Free	Free	Free	Free	Free
★08-00217-06040		40					100	10,000	Free	Free	Free	Free	Free
★08-00217-06050		50					110	14,000	Free	Free	Free	Free	Free

P プリハードン鋼
Prehardened Steel

M ステンレス鋼
Stainless Steel

S チタン合金
耐熱合金
Titanium Alloy
Heat Resistant Alloy

H 高硬度鋼
Hardened Steel
~55 HRC
~65 HRC

ロングネック
スクエア
エンドミル
コーティング
Coating

MHRH430

切削条件参考表

Recommended Milling Conditions

被削材 Work Material		炭素鋼・調質鋼 Carbon Steels・Prehardened Steels S50C・NAK55・NAK80・HPM1 (~43HRC)				高硬度鋼 Hardened Steels HPM38・STAVAX・SKD61 (~55HRC)				高硬度鋼 Hardened Steels SKD11・PD613 (~62HRC)				ハイス High Speed Steels SKH (~65HRC)			
外径 Dia.	首下長 Under Neck Length	回転数 Spindle Speed	送り速度 Feed	切込み量 Depth of Cut		回転数 Spindle Speed	送り速度 Feed	切込み量 Depth of Cut		回転数 Spindle Speed	送り速度 Feed	切込み量 Depth of Cut		回転数 Spindle Speed	送り速度 Feed	切込み量 Depth of Cut	
		min ⁻¹	mm/min	ap mm	ae mm	min ⁻¹	mm/min	ap mm	ae mm	min ⁻¹	mm/min	ap mm	ae mm	min ⁻¹	mm/min	ap mm	ae mm
1	4	25,000	2,000	0.05	0.6	23,000	1,800	0.04	0.5	18,000	1,600	0.03	0.4	14,000	1,000	0.02	0.3
	6	20,000	1,800	0.03	0.6	18,000	1,400	0.02	0.5	14,000	1,200	0.01	0.4	10,000	800	0.007	0.3
	8	18,000	1,600	0.03	0.6	16,000	1,200	0.02	0.5	12,000	1,000	0.01	0.4	8,000	680	0.005	0.3
	10	16,000	1,200	0.02	0.6	14,000	1,000	0.01	0.5	10,000	800	0.007	0.4	6,000	500	0.005	0.3
1.2	6	20,000	1,800	0.04	0.7	18,000	1,400	0.03	0.6	14,000	1,200	0.02	0.5	10,000	800	0.01	0.4
	8	18,000	1,600	0.04	0.7	16,000	1,200	0.02	0.6	12,000	1,000	0.01	0.5	8,000	680	0.007	0.4
	10	16,000	1,200	0.03	0.7	12,000	1,000	0.02	0.6	10,000	850	0.01	0.5	8,000	600	0.005	0.4
	12	14,000	1,200	0.02	0.7	10,000	1,000	0.01	0.6	9,000	800	0.007	0.5	7,000	500	0.005	0.4
1.5	6	23,000	2,000	0.06	0.9	20,000	1,600	0.04	0.75	18,000	1,400	0.03	0.6	14,000	1,000	0.02	0.45
	8	20,000	1,800	0.06	0.9	18,000	1,200	0.03	0.75	14,000	1,200	0.03	0.6	10,000	750	0.01	0.45
	10	20,000	1,600	0.04	0.9	16,000	1,000	0.03	0.75	14,000	1,000	0.02	0.6	10,000	700	0.01	0.45
	12	16,000	1,400	0.04	0.9	14,000	1,000	0.02	0.75	12,000	850	0.02	0.6	8,000	620	0.007	0.45
	14	14,000	1,200	0.03	0.9	12,000	800	0.02	0.75	10,000	750	0.01	0.6	7,500	500	0.007	0.45
1.8	6	20,000	2,000	0.07	1	18,000	1,800	0.05	0.9	15,000	1,500	0.04	0.7	12,000	1,200	0.03	0.5
	8	18,000	1,800	0.06	1	16,000	1,600	0.04	0.9	12,000	1,200	0.03	0.7	9,500	1,000	0.02	0.5
	10	16,000	1,600	0.06	1	14,000	1,400	0.04	0.9	12,000	1,000	0.03	0.7	9,500	900	0.02	0.5
	12	14,000	1,400	0.05	1	12,000	1,200	0.03	0.9	10,000	1,000	0.02	0.7	8,200	800	0.01	0.5
	14	14,000	1,400	0.05	1	12,000	1,200	0.03	0.9	10,000	860	0.02	0.7	8,200	720	0.01	0.5
	16	12,000	1,200	0.04	1	10,000	1,000	0.02	0.9	9,200	800	0.01	0.7	7,500	680	0.007	0.5
	18	10,000	1,000	0.04	1	9,200	820	0.02	0.9	8,500	740	0.01	0.7	6,000	640	0.007	0.5
2	6	20,000	2,000	0.08	1.2	18,000	1,800	0.06	1	15,000	1,500	0.05	0.8	12,000	1,200	0.03	0.6
	8	18,000	1,800	0.07	1.2	16,000	1,600	0.05	1	12,000	1,200	0.04	0.8	9,500	1,000	0.02	0.6
	10	16,000	1,600	0.06	1.2	14,000	1,400	0.05	1	12,000	1,000	0.04	0.8	9,500	900	0.02	0.6
	12	14,000	1,400	0.05	1.2	12,000	1,200	0.04	1	10,000	1,000	0.03	0.8	8,200	800	0.01	0.6
	14	14,000	1,400	0.04	1.2	12,000	1,200	0.03	1	10,000	860	0.02	0.8	8,200	720	0.007	0.6
	16	12,000	1,200	0.04	1.2	10,000	1,000	0.03	1	9,200	800	0.02	0.8	7,500	680	0.007	0.6
	18	10,000	1,000	0.03	1.2	9,200	820	0.02	1	8,500	740	0.01	0.8	6,000	640	0.005	0.6
	20	10,000	800	0.03	1.2	9,200	760	0.02	1	8,500	680	0.01	0.8	6,000	520	0.005	0.6
2.5	8	16,000	2,000	0.08	1.5	14,000	1,600	0.07	1.25	10,000	1,400	0.05	1	8,000	1,000	0.03	0.75
	12	14,000	1,600	0.07	1.5	12,000	1,400	0.06	1.25	9,600	1,200	0.04	1	7,500	960	0.02	0.75
	16	12,000	1,400	0.06	1.5	10,000	1,200	0.05	1.25	8,500	1,000	0.02	1	7,000	800	0.01	0.75
	20	10,000	1,200	0.06	1.5	8,200	1,000	0.05	1.25	7,500	1,000	0.02	1	5,000	800	0.01	0.75
	25	8,000	1,000	0.05	1.5	7,000	800	0.03	1.25	6,500	680	0.01	1	4,500	550	0.005	0.75

レギュラーライン
無限プレミアム
ロングネックタイプ

Regular Line
MUGEN PREMIUM
Long Neck Type

プリハードン鋼 P
Prehardened Steel

ステンレス鋼 M
Stainless Steel

チタン合金 S
耐熱合金
Titanium Alloy
Heat Resistant Alloy

~55 HRC
高硬度鋼 H
Hardened Steel

Coating
「リネア」
Long Neck
ロングネック
タイプ
スクエア

切削条件参考表

Recommended Milling Conditions

被削材 Work Material		炭素鋼・調質鋼 Carbon Steels・Prehardened Steels S50C・NAK55・NAK80 HPM1 (~43HRC)				高硬度鋼 Hardened Steels HPM38・STAVAX・SKD61 (~55HRC)				高硬度鋼 Hardened Steels SKD11・PD613 (~62HRC)				ハイス High Speed Steels SKH (~65HRC)					
外径 Dia.	首下長 Under Neck Length	回転数 Spindle Speed		送り速度 Feed		切込み量 Depth of Cut		回転数 Spindle Speed		送り速度 Feed		切込み量 Depth of Cut		回転数 Spindle Speed		送り速度 Feed		切込み量 Depth of Cut	
		min ⁻¹	mm/min	ap mm	ae mm	min ⁻¹	mm/min	ap mm	ae mm	min ⁻¹	mm/min	ap mm	ae mm	min ⁻¹	mm/min	ap mm	ae mm		
3	8	16,000	2,000	0.15	1.8	14,000	1,800	0.1	1.5	10,000	1,600	0.07	1.2	8,000	1,200	0.05	0.9		
	12	14,000	1,800	0.1	1.8	12,000	1,600	0.08	1.5	9,200	1,400	0.06	1.2	7,200	1,000	0.04	0.9		
	16	12,000	1,600	0.08	1.8	10,000	1,400	0.07	1.5	8,500	1,200	0.05	1.2	6,500	800	0.03	0.9		
	20	10,000	1,600	0.08	1.8	9,000	1,400	0.07	1.5	7,800	1,200	0.04	1.2	5,800	800	0.02	0.9		
	25	9,000	1,400	0.07	1.8	8,200	1,200	0.06	1.5	7,000	1,000	0.03	1.2	5,000	720	0.01	0.9		
	30	8,000	1,400	0.05	1.8	7,000	1,200	0.03	1.5	6,500	1,000	0.02	1.2	4,500	650	0.007	0.9		
4	12	12,000	2,000	0.2	2.5	9,500	2,000	0.15	2	8,000	1,600	0.08	1.6	7,000	1,000	0.06	1.2		
	16	10,000	2,000	0.15	2.5	8,000	1,800	0.1	2	7,000	1,400	0.06	1.6	6,000	1,200	0.05	1.2		
	20	8,500	1,800	0.12	2.5	7,000	1,600	0.08	2	6,500	1,200	0.05	1.6	5,500	1,000	0.04	1.2		
	25	8,000	1,600	0.1	2.5	6,000	1,400	0.07	2	5,200	1,200	0.04	1.6	4,500	1,000	0.03	1.2		
	30	6,800	1,400	0.08	2.5	4,800	1,000	0.05	2	4,200	850	0.03	1.6	3,500	620	0.02	1.2		
	35	5,500	1,000	0.07	2.5	4,200	880	0.04	2	3,800	720	0.02	1.6	3,000	550	0.01	1.2		
5	16	10,000	2,000	0.2	3	7,000	1,800	0.12	2.5	5,500	1,600	0.08	2	4,500	1,000	0.06	1.5		
	25	8,000	1,600	0.15	3	5,800	1,400	0.07	2.5	4,200	1,200	0.05	2	3,000	800	0.03	1.5		
	35	6,000	1,200	0.1	3	4,200	900	0.05	2.5	3,500	800	0.03	2	2,500	600	0.02	1.5		
	50	3,500	750	0.07	3	2,800	620	0.03	2.5	2,500	500	0.02	2	1,500	350	0.01	1.5		
6	20	8,000	2,000	0.25	4	6,500	1,600	0.18	3	4,500	1,400	0.08	2.4	3,500	920	0.06	1.8		
	30	7,000	1,600	0.2	4	4,500	1,200	0.12	3	3,500	1,000	0.06	2.4	2,500	660	0.04	1.8		
	40	4,500	1,200	0.15	4	3,000	1,000	0.08	3	2,500	800	0.03	2.4	2,000	550	0.02	1.8		
	50	3,000	850	0.1	4	2,500	700	0.05	3	2,000	500	0.02	2.4	1,500	380	0.01	1.8		

備考 Notes

- ※1 本切削条件は参考値です。実際の加工形状および使用機械等にて切削条件を調整してください。
- ※2 切込み量の、apは軸方向の切込み深さ、aeは半径方向の切込み深さを示します。
- ※3 高硬度鋼を切削加工する場合は、オイルミストクーラントをお奨めします。
- ※4 Z切込み時のアプローチ方法として、ヘリカル（螺旋）及びランプ（傾斜）での切削加工をお奨めします。
- ※5 L（首下長）/D（外径）が8倍を超える場合は立ち壁付近の送り速度を50%以下、切込み量：aeを30%以下に調整してください。
- ※6 溝切削は、切削条件参考表を参考に切込み量：ap及び送り速度を50%以下に設定し、往復切削をお奨めします。
- ※7 びびりが発生する場合は、回転数と送り速度を同じ割合で下げてください。また、主軸回転数が足りない場合も同様に同じ割合で下げてください。
- ※1 These recommended cutting conditions indicate just reference. It should be adjusted according to milling shape and machine type.
- ※2 ap:Axial Depth of Cut, ae:Radial Depth of Cut.
- ※3 Recommend to use oil mist coolant for machining hardened steel.
- ※4 Recommend to apply helical or ramping for approaching into axial direction.
- ※5 Adjust feed rate 50% lower and cutting depth (ae) 30% lower for milling deep wall area. When L/D exceeds 8 for stable milling.
- ※6 For slotting, recommend reciprocating milling by adjusting feed & ap in below 50% of recommended milling condition.
- ※7 Reduce both spindle speed and feed at same rate for chatter and also for insufficient spindle speed of a machine.

P プリハードン鋼
Prehardened Steel

M ステンレス鋼
Stainless Steel

S チタン合金
耐熱合金
Titanium Alloy
Heat Resistant Alloy

H 高硬度鋼
Hardened Steel

~ 55 HRC

~ 65 HRC



MRBH230

サイズ
Size R0.05 ~ R3

∞ Premium ≤ 65 HRC

無限コーティングプレミアム 高硬度用2枚刃ロングネックボールエンドミル

MUGEN COATING PREMIUM 2-Flute Long Neck Ball End Mill for Hardened Steel

調質鋼・高硬度鋼 (~65HRC) 対応の
ロングネックボールエンドミル。L/Dは最大22倍

Long neck ball end mill for prehardened steels and hardened steels (~ 65HRC). Maximum L/D=22

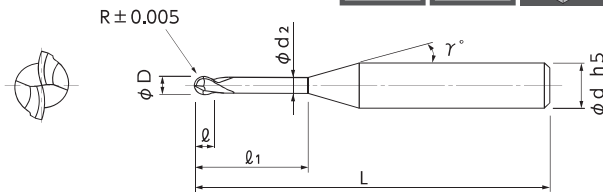

- 高硬度鋼用の無限コーティングプレミアムと独自の新形状により耐チッピング性に優れ、びびりを抑えることにより仕上げ面が向上。
- 65HRCまでの高硬度鋼に対応。
- 全224サイズ!
- MUGEN COATING PREMIUM for hardened steels and unique new design excel in chipping prevention and resolves chattering to realize excellent finished surface.
- Applicable for hardened steels up to 65HRC.
- Total 224 sizes!

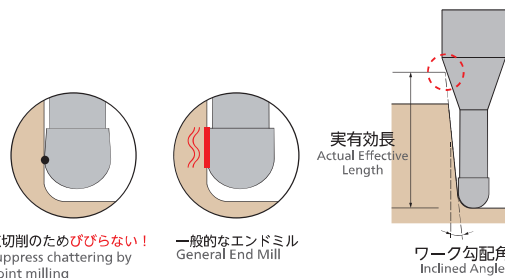

レギュラーライン
無限プレミアム
ロングネックタイプ

Regular Line
MUGEN PREMIUM
Long Neck Type

プリハードン鋼
Prehardened Steel P

ステンレス鋼
Stainless Steel M

チタン合金
耐熱合金
Titanium Alloy
Heat Resistant Alloy S

~ 55 HRC
高硬度鋼
Hardened Steel H

~ 65 HRC
高硬度鋼
Hardened Steel H

コーティング
ロングネック
ボールエンドミル

★再研磨可能 (シャンク長15mm以上のもの。詳細はお問い合わせください。)

単位 [寸法 : mm / 価格 : 円]
Unit [Size : mm / Retail Price : JPY]

コードNo. Code No.	(R) ボール半径 Radius	(l ₁) 首下長 Under Neck Length	(l) 刃長 Length of Cut	(D) 外径 Dia.	(d ₂) 首下径 Neck Dia.	(γ) 首角 Neck Taper Angle	(d) シャンク径 Shank Dia.	(L) 全長 Overall Length	標準価格 Retail Price	ワーク勾配角に対する実有効長 Actual effective length depending on inclined angle of workpiece.				
										30°	1°	1°30'	2°	3°
08-00527-00050	R0.05	0.2	0.07	0.1	0.085	12°	4	45	11,700	0.24	0.25	0.26	0.27	0.29
08-00527-00051		0.3	0.07	0.1	0.085	12°	4	45	10,300	0.34	0.36	0.37	0.39	0.42
08-00527-00053		0.5	0.07	0.1	0.085	12°	4	45	11,200	0.55	0.57	0.60	0.63	0.69
08-00527-00071	R0.075	0.3	0.1	0.15	0.13	12°	4	45	12,000	0.36	0.37	0.39	0.40	0.44
08-00527-00073		0.5	0.1	0.15	0.13	12°	4	45	12,700	0.59	0.59	0.61	0.64	0.70
08-00527-00075		1	0.1	0.15	0.13	12°	4	45	13,500	1.09	1.13	1.18	1.24	1.37
08-00527-00100	R0.1	0.3	0.15	0.2	0.18	12°	4	45	7,200	0.35	0.36	0.38	0.39	0.42
08-00527-00101		0.5	0.15	0.2	0.18	12°	4	45	7,200	0.56	0.58	0.61	0.63	0.69
08-00527-00102		0.75	0.15	0.2	0.18	12°	4	45	7,200	0.82	0.85	0.89	0.93	1.02
08-00527-00103		1	0.15	0.2	0.18	12°	4	45	7,200	1.08	1.13	1.18	1.23	1.35
08-00528-00103		1	0.15	0.2	0.18	12°	6	50	10,200	1.08	1.13	1.18	1.23	1.35
08-00527-00104		1.25	0.15	0.2	0.18	12°	4	45	7,800	1.34	1.40	1.46	1.53	1.68
08-00527-00105		1.5	0.15	0.2	0.18	12°	4	45	7,800	1.60	1.67	1.75	1.83	2.02
08-00527-00106		1.75	0.15	0.2	0.18	12°	4	45	8,700	1.86	1.94	2.03	2.13	2.35
08-00527-00107		2	0.15	0.2	0.18	12°	4	45	8,700	2.13	2.22	2.32	2.43	2.68
08-00527-00108		2.5	0.15	0.2	0.18	12°	4	45	9,500	2.65	2.76	2.89	3.02	3.34
08-00527-00109	3	0.15	0.2	0.18	12°	4	45	10,200	3.17	3.31	3.46	3.62	4.01	

オーダー方法
How to Order

MRBH230 ボール半径 (R) × 首下長 (l₁) × シャンク径 (d) を指示してください。
When you order, indicate MRBH230 (R) × (l₁) × (d).

※ (γ) は参考値です。
※ (γ) is reference value.

無限コーティングプレミアム 高硬度用2枚刃ロングネックボールエンドミル

MUGEN COATING PREMIUM 2-Flute Long Neck Ball End Mill for Hardened Steel

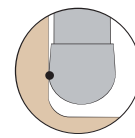

点切削のためびびらない!
Suppress chattering by
point milling

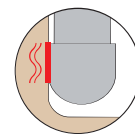

一般的なエンドミル
General End Mill

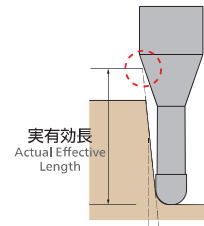

実有効長
Actual Effective
Length
ワーク勾配角
Inclined Angle

コードNo. Code No.	(R)ボール半径 Radius	(ℓ ₁)首下長 Under Neck Length	(ℓ)刃長 Length of Cut	(D)外径 Dia.	(d ₂)首下径 Neck Dia.	(γ)首角 Neck Taper Angle	(d)シャンク径 Shank Dia.	(L)全長 Overall Length	標準価格 Retail Price	ワーク勾配角に対する実有効長 Actual effective length depending on inclined angle of workpiece.				
										30°	1°	1°30'	2°	3°
08-00527-00162	R0.15	0.5	0.2	0.3	0.28	12°	4	45	7,100	0.56	0.58	0.60	0.63	0.68
08-00527-00150		0.6	0.2	0.3	0.28	12°	4	45	7,100	0.66	0.69	0.71	0.74	0.81
08-00527-00163		0.75	0.2	0.3	0.28	12°	4	45	7,100	0.82	0.86	0.89	0.93	1.01
08-00527-00151		1	0.2	0.3	0.28	12°	4	45	7,100	1.08	1.12	1.17	1.22	1.34
08-00527-00152		1.25	0.2	0.3	0.28	12°	4	45	7,600	1.34	1.39	1.45	1.52	1.67
08-00527-00153		1.5	0.2	0.3	0.28	12°	4	45	7,600	1.60	1.67	1.74	1.82	2.00
08-00528-00153		1.5	0.2	0.3	0.28	12°	6	50	10,700	1.60	1.67	1.74	1.82	2.00
08-00527-00154		1.75	0.2	0.3	0.28	12°	4	45	7,600	1.86	1.94	2.02	2.12	2.33
08-00527-00155		2	0.2	0.3	0.28	12°	4	45	7,600	2.12	2.21	2.31	2.42	2.66
08-00527-00156		2.25	0.2	0.3	0.28	12°	4	45	7,800	2.38	2.48	2.59	2.71	3.00
08-00527-00157		2.5	0.2	0.3	0.28	12°	4	45	7,800	2.64	2.76	2.88	3.01	3.33
08-00527-00159		3	0.2	0.3	0.28	12°	4	45	7,800	3.17	3.30	3.45	3.61	3.99
08-00527-00160		3.5	0.2	0.3	0.28	12°	4	45	8,200	3.69	3.85	4.02	4.21	4.65
08-00527-00161		4	0.2	0.3	0.28	12°	4	45	8,200	4.21	4.39	4.59	4.81	5.32
08-00527-00211	R0.2	0.5	0.3	0.4	0.37	12°	4	45	4,900	0.59	0.60	0.62	0.64	0.69
08-00527-00201		0.8	0.3	0.4	0.37	12°	4	45	4,900	0.89	0.93	0.96	1.00	1.09
08-00527-00202		1	0.3	0.4	0.37	12°	4	45	4,900	1.10	1.14	1.19	1.24	1.35
08-00528-00202		1	0.3	0.4	0.37	12°	6	50	7,200	1.10	1.14	1.19	1.24	1.35
08-00527-00203		1.5	0.3	0.4	0.37	12°	4	45	5,000	1.62	1.69	1.76	1.84	2.02
08-00527-00204		2	0.3	0.4	0.37	12°	4	45	5,100	2.15	2.23	2.33	2.43	2.68
08-00528-00204		2	0.3	0.4	0.37	12°	6	50	7,500	2.15	2.23	2.33	2.43	2.68
08-00527-00205		2.5	0.3	0.4	0.37	12°	4	45	5,300	2.67	2.78	2.90	3.03	3.34
08-00527-00206		3	0.3	0.4	0.37	12°	4	45	5,600	3.19	3.32	3.47	3.63	4.01
08-00527-00207		3.5	0.3	0.4	0.37	12°	4	45	6,100	3.71	3.87	4.04	4.23	4.67
08-00527-00208		4	0.3	0.4	0.37	12°	4	45	6,100	4.23	4.41	4.61	4.83	5.33
08-00527-00209		4.5	0.3	0.4	0.37	12°	4	45	6,400	4.75	4.96	5.18	5.43	6.00
08-00527-00210		5	0.3	0.4	0.37	12°	4	45	6,400	5.27	5.50	5.75	6.02	6.66
08-00527-00212		6	0.3	0.4	0.37	12°	4	45	7,500	6.33	6.60	6.90	7.23	8.00
08-00527-00250	R0.25	1	0.35	0.5	0.46	12°	4	45	4,900	1.13	1.16	1.21	1.26	1.37
08-00527-00251		1.5	0.35	0.5	0.46	12°	4	45	4,900	1.65	1.71	1.78	1.85	2.03
08-00527-00252		2	0.35	0.5	0.46	12°	4	45	4,900	2.17	2.25	2.35	2.45	2.69
08-00527-00253		2.5	0.35	0.5	0.46	12°	4	45	4,900	2.69	2.80	2.92	3.05	3.36
08-00527-00254		3	0.35	0.5	0.46	12°	4	45	4,900	3.21	3.34	3.49	3.65	4.02
08-00527-00255		3.5	0.35	0.5	0.46	12°	4	45	4,900	3.73	3.89	4.06	4.25	4.69
08-00527-00256		4	0.35	0.5	0.46	12°	4	45	4,900	4.25	4.43	4.63	4.85	5.35
08-00527-00257		4.5	0.35	0.5	0.46	12°	4	45	5,000	4.78	4.98	5.20	5.44	6.01
08-00527-00258		5	0.35	0.5	0.46	12°	4	45	5,000	5.30	5.52	5.77	6.04	6.68
08-00527-00259		5.5	0.35	0.5	0.46	12°	4	45	5,100	5.82	6.07	6.34	6.64	7.34
08-00527-00260	6	0.35	0.5	0.46	12°	4	45	5,100	6.34	6.61	6.91	7.24	8.00	
08-00527-00262	8	0.35	0.5	0.46	12°	4	45	6,100	8.42	8.79	9.19	9.63	10.66	
08-00527-00264	10	0.35	0.5	0.46	12°	4	45	7,700	10.52	10.98	11.49	12.04	13.35	
08-00527-00300	R0.3	1	0.45	0.6	0.56	12°	4	45	4,200	1.12	1.16	1.20	1.25	1.35
08-00527-00301		1.5	0.45	0.6	0.56	12°	4	45	3,800	1.64	1.71	1.77	1.84	2.02
08-00527-00302		2	0.45	0.6	0.56	12°	4	45	3,800	2.17	2.25	2.34	2.44	2.68
08-00528-00302		2	0.45	0.6	0.56	12°	6	50	5,800	2.17	2.25	2.34	2.44	2.68
08-00527-00303		2.5	0.45	0.6	0.56	12°	4	45	3,900	2.69	2.79	2.91	3.04	3.34
08-00527-00304		3	0.45	0.6	0.56	12°	4	45	3,900	3.21	3.34	3.48	3.64	4.01
08-00528-00304		3	0.45	0.6	0.56	12°	6	50	5,900	3.21	3.34	3.48	3.64	4.01
08-00527-00305		3.5	0.45	0.6	0.56	12°	4	45	4,000	3.73	3.88	4.05	4.24	4.67
08-00527-00306		4	0.45	0.6	0.56	12°	4	45	4,000	4.25	4.43	4.62	4.84	5.33
08-00528-00306		4	0.45	0.6	0.56	12°	6	50	6,100	4.25	4.43	4.62	4.84	5.33
08-00527-00321		4.5	0.45	0.6	0.56	12°	4	45	4,000	4.78	4.98	5.20	5.45	6.02
08-00527-00308		5	0.45	0.6	0.56	12°	4	45	4,000	5.29	5.52	5.76	6.03	6.66
08-00527-00322		5.5	0.45	0.6	0.56	12°	4	45	4,000	5.82	6.07	6.34	6.64	7.35
08-00527-00310		6	0.45	0.6	0.56	12°	4	45	4,000	6.34	6.61	6.90	7.23	7.99

P プリハードン鋼
Prehardened Steel

M ステンレス鋼
Stainless Steel

S チタン合金
耐熱合金
Titanium Alloy
Heat Resistant Alloy

H 高硬度鋼
Hardened Steel

~ 55 HRC

~ 65 HRC

ロングネック
Long Neck
ボールエンドミル
Ball End Mill
コーティング
Coating

MRBH230

無限コーティングプレミアム 高硬度用2枚刃ロングネックボールエンドミル

MUGEN COATING PREMIUM 2-Flute Long Neck Ball End Mill for Hardened Steel

レギュラーライン
無限プレミアム
ロングネックタイプ

Regular Line
MUGEN PREMIUM
Long Neck Type

アリハードン鋼 P
Prehardened Steel

ステンレス鋼 M
Stainless Steel

チタン合金
耐熱合金 S
Titanium Alloy
Heat Resistant Alloy

~55 HRC
~65 HRC
高硬度鋼 H
Hardened Steel

コーティング
ロングネック
ボールエンドミル

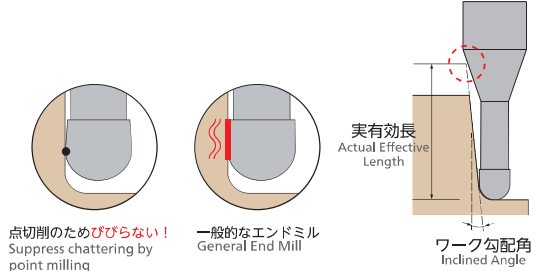

点切削のためびびらない!
Suppress chatter by
point milling

一般的なエンドミル
General End Mill

実有効長
Actual Effective
Length
ワーク勾配角
Inclined Angle

★再研磨可能 (シャンク長15mm以上のもの。詳細はお問い合わせください。)

単位 [寸法: mm / 価格: 円]
Unit [Size: mm / Retail Price: JPY]

コードNo. Code No.	(R)ボール半径 Radius	(ℓ1)首下長 Under Neck Length	(ℓ)刃長 Length of Cut	(D)外径 Dia.	(d2)首下径 Neck Dia.	(γ)首角 Neck Taper Angle	(d)シャンク径 Shank Dia.	(L)全長 Overall Length	標準価格 Retail Price	ワーク勾配角に対する実有効長 Actual effective length depending on inclined angle of workpiece.				
										30°	1°	1°30'	2°	3°
08-00527-00312	R0.3	7	0.45	0.6	0.56	12°	4	45	4,500	7.38	7.70	8.04	8.43	9.31
08-00527-00314		8	0.45	0.6	0.56	12°	4	45	5,300	8.42	8.79	9.18	9.62	10.64
08-00527-00316		9	0.45	0.6	0.56	12°	4	45	5,600	9.47	9.88	10.33	10.82	11.97
08-00527-00318		10	0.45	0.6	0.56	12°	4	45	5,400	10.51	10.97	11.47	12.02	13.30
08-00527-00320		12	0.45	0.6	0.56	12°	4	45	6,100	12.59	13.14	13.75	14.41	15.95
08-00527-00350	R0.35	2	0.5	0.7	0.66	12°	4	45	4,300	2.17	2.25	2.34	2.44	2.67
08-00527-00351		4	0.5	0.7	0.66	12°	4	45	4,600	4.25	4.43	4.62	4.84	5.33
08-00527-00352		6	0.5	0.7	0.66	12°	4	45	4,600	6.34	6.61	6.91	7.23	8.00
08-00527-00353		8	0.5	0.7	0.66	12°	4	45	4,600	8.43	8.79	9.19	9.63	10.66
08-00527-00401	R0.4	2	0.6	0.8	0.76	12°	4	45	3,800	2.16	2.24	2.33	2.42	2.65
08-00528-00401		2	0.6	0.8	0.76	12°	6	50	5,800	2.16	2.24	2.33	2.42	2.65
08-00527-00402		3	0.6	0.8	0.76	12°	4	45	4,000	3.20	3.33	3.47	3.62	3.97
08-00527-00403		4	0.6	0.8	0.76	12°	4	45	4,000	4.25	4.42	4.61	4.82	5.30
08-00527-00404		5	0.6	0.8	0.76	12°	4	45	4,000	5.29	5.51	5.75	6.01	6.63
08-00527-00405		6	0.6	0.8	0.76	12°	4	45	4,000	6.33	6.60	6.89	7.21	7.96
08-00527-00406		7	0.6	0.8	0.76	12°	4	45	4,000	7.38	7.69	8.03	8.41	9.28
08-00527-00407		8	0.6	0.8	0.76	12°	4	45	4,000	8.42	8.78	9.17	9.60	10.61
08-00527-00409		10	0.6	0.8	0.76	12°	4	45	5,300	10.50	10.96	11.45	12.00	13.26
08-00527-00410		12	0.6	0.8	0.76	12°	4	45	5,800	12.59	13.14	13.73	14.39	15.92
08-00527-00450	R0.45	2	0.65	0.9	0.86	12°	4	45	4,300	2.16	2.24	2.33	2.42	2.64
08-00527-00451		4	0.65	0.9	0.86	12°	4	45	4,600	4.25	4.42	4.61	4.82	5.30
08-00527-00452		6	0.65	0.9	0.86	12°	4	45	4,600	6.34	6.60	6.89	7.21	7.96
08-00527-00453		8	0.65	0.9	0.86	12°	4	45	4,600	8.42	8.78	9.17	9.61	10.62
★08-00527-00500	R0.5	2	0.75	1	0.95	12°	4	45	3,200	2.18	2.26	2.34	2.43	2.65
★08-00527-00514		2.5	0.75	1	0.95	12°	4	45	3,200	2.71	2.81	2.92	3.04	3.32
★08-00527-00501		3	0.75	1	0.95	12°	4	45	3,200	3.22	3.35	3.48	3.63	3.97
★08-00528-00501		3	0.75	1	0.95	12°	6	50	5,100	3.22	3.35	3.48	3.63	3.97
★08-00527-00502		4	0.75	1	0.95	12°	4	45	3,600	4.27	4.44	4.62	4.83	5.30
★08-00528-00502		4	0.75	1	0.95	12°	6	50	5,600	4.27	4.44	4.62	4.83	5.30
★08-00527-00503		5	0.75	1	0.95	12°	4	45	3,600	5.31	5.53	5.76	6.02	6.63
★08-00528-00503		5	0.75	1	0.95	12°	6	50	5,600	5.31	5.53	5.76	6.02	6.63
★08-00527-00504		6	0.75	1	0.95	12°	4	45	3,900	6.35	6.62	6.90	7.22	7.96
★08-00528-00504		6	0.75	1	0.95	12°	6	50	5,900	6.35	6.62	6.90	7.22	7.96
★08-00527-00505		7	0.75	1	0.95	12°	4	45	3,900	7.40	7.71	8.04	8.42	9.28
★08-00528-00505		7	0.75	1	0.95	12°	6	50	5,900	7.40	7.71	8.04	8.42	9.28
★08-00527-00506		8	0.75	1	0.95	12°	4	45	3,900	8.44	8.79	9.18	9.61	10.61
★08-00528-00506		8	0.75	1	0.95	12°	6	50	5,900	8.44	8.79	9.18	9.61	10.61
★08-00527-00507	9	0.75	1	0.95	12°	4	45	3,900	9.48	9.88	10.32	10.81	11.94	
★08-00527-00508	10	0.75	1	0.95	12°	4	45	3,900	10.52	10.97	11.46	12.01	13.26	
★08-00528-00508	10	0.75	1	0.95	12°	6	50	5,900	10.52	10.97	11.46	12.01	13.26	
★08-00527-00509	12	0.75	1	0.95	12°	4	45	3,900	12.61	13.15	13.75	14.40	15.92	
★08-00527-00515	13	0.75	1	0.95	12°	4	45	4,500	13.66	14.25	14.90	15.62	17.29	
★08-00527-00510	14	0.75	1	0.95	12°	4	50	4,500	14.70	15.33	16.03	16.79	18.57	

オーダー方法
How to Order

MRBH230 ボール半径(R)×首下長(ℓ1)×シャンク径(d)を指示してください。
When you order, indicate MRBH230 (R)×(ℓ1)×(d).

※(γ)は参考値です。
※(γ) is reference value.

無限コーティングプレミアム 高硬度用2枚刃ロングネックボールエンドミル

MUGEN COATING PREMIUM 2-Flute Long Neck Ball End Mill for Hardened Steel

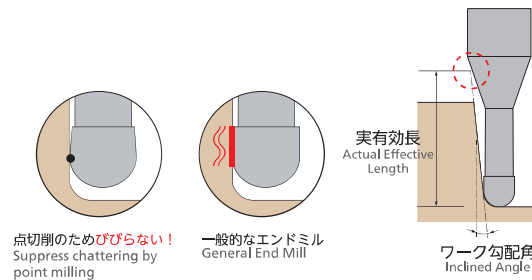

P プリハードン鋼
Prehardened Steel

M ステンレス鋼
Stainless Steel

コードNo. Code No.	(R)ボール半径 Radius	(ℓ1)首下長 Under Neck Length	(ℓ)刃長 Length of Cut	(D)外径 Dia.	(d2)首下径 Neck Dia.	(γ)首角 Neck Taper Angle	(d)シャンク径 Shank Dia.	(L)全長 Overall Length	標準価格 Retail Price	ワーク勾配角に対する実有効長 Actual effective length depending on inclined angle of workpiece.				
										30°	1°	1°30'	2°	3°
★ 08-00527-00511	R0.5	16	0.75	1	0.95	12°	4	50	5,300	16.78	17.51	18.31	19.18	21.23
★ 08-00527-00512		18	0.75	1	0.95	12°	4	55	5,300	18.87	19.69	20.59	21.58	23.88
★ 08-00527-00513		20	0.75	1	0.95	12°	4	55	6,400	20.95	21.87	22.87	23.97	26.54
★ 08-00528-00516		22	0.75	1	0.95	12°	6	60	9,600	22.82	23.59	24.43	25.33	27.34
★ 08-00527-00600	R0.6	2.4	0.9	1.2	1.15	12°	4	45	4,800	2.59	2.68	2.78	2.89	3.15
★ 08-00527-00601		4	0.9	1.2	1.15	12°	4	45	4,800	4.26	4.43	4.61	4.81	5.27
★ 08-00527-00602		6	0.9	1.2	1.15	12°	4	45	5,200	6.35	6.61	6.89	7.20	7.92
★ 08-00527-00603		8	0.9	1.2	1.15	12°	4	45	5,200	8.43	8.79	9.17	9.59	10.58
★ 08-00527-00604		10	0.9	1.2	1.15	12°	4	45	5,200	10.52	10.96	11.45	11.99	13.23
★ 08-00527-00605		12	0.9	1.2	1.15	12°	4	45	5,200	12.61	13.14	13.73	14.38	15.89
★ 08-00527-00606		14	0.9	1.2	1.15	12°	4	50	5,700	14.69	15.32	16.01	16.77	18.54
★ 08-00527-00607		16	0.9	1.2	1.15	12°	4	50	6,200	16.78	17.50	18.29	19.17	21.20
★ 08-00527-00700	R0.7	8	1	1.4	1.35	12°	4	45	4,500	8.44	8.78	9.17	9.59	10.57
★ 08-00527-00701		12	1	1.4	1.35	12°	4	50	4,500	12.61	13.14	13.73	14.38	15.90
★ 08-00527-00702		16	1	1.4	1.35	12°	4	50	4,500	16.78	17.50	18.30	19.17	21.22
★ 08-00527-00750		3	1.1	1.5	1.45	12°	4	45	3,700	3.21	3.33	3.45	3.58	3.89
★ 08-00527-00751	R0.75	4	1.1	1.5	1.45	12°	4	45	3,700	4.26	4.41	4.59	4.78	5.22
★ 08-00527-00753		6	1.1	1.5	1.45	12°	4	45	3,700	6.34	6.59	6.87	7.17	7.88
★ 08-00528-00753		6	1.1	1.5	1.45	12°	6	50	6,000	6.34	6.59	6.87	7.17	7.88
★ 08-00527-00755		8	1.1	1.5	1.45	12°	4	45	3,900	8.43	8.77	9.15	9.56	10.53
★ 08-00528-00755		8	1.1	1.5	1.45	12°	6	50	6,000	8.43	8.77	9.15	9.56	10.53
★ 08-00527-00757		10	1.1	1.5	1.45	12°	4	45	4,200	10.51	10.95	11.43	11.96	13.18
★ 08-00527-00758		12	1.1	1.5	1.45	12°	4	45	4,500	12.60	13.13	13.71	14.35	15.84
★ 08-00527-00759		14	1.1	1.5	1.45	12°	4	50	4,500	14.69	15.31	15.99	16.74	18.49
★ 08-00527-00760		16	1.1	1.5	1.45	12°	4	50	4,500	16.77	17.49	18.27	19.14	21.15
★ 08-00527-00761		18	1.1	1.5	1.45	12°	4	55	4,500	18.86	19.68	20.57	21.56	23.87
★ 08-00527-00762		20	1.1	1.5	1.45	12°	4	55	4,500	20.94	21.85	22.84	23.92	Free
★ 08-00527-00763		22	1.1	1.5	1.45	12°	4	60	4,500	23.03	24.02	25.12	26.32	Free
★ 08-00527-00764		30	1.1	1.5	1.45	12°	4	70	4,500	31.37	32.74	34.24	35.89	Free
★ 08-00527-00803		R0.8	8	1.2	1.6	1.55	12°	4	45	5,200	8.43	8.77	9.14	9.55
★ 08-00527-00805	12		1.2	1.6	1.55	12°	4	45	5,200	12.60	13.13	13.70	14.34	15.82
★ 08-00527-00807	16		1.2	1.6	1.55	12°	4	50	5,200	16.77	17.48	18.27	19.13	21.13
★ 08-00527-00809	20		1.2	1.6	1.55	12°	4	55	5,200	20.94	21.84	22.83	23.91	Free

S チタン合金
耐熱合金
Titanium Alloy
Heat Resistant Alloy

H 高硬度鋼
Hardened Steel

~ 55 HRC

~ 65 HRC

ロングネック
ボールエンドミル
コーティング

MRBH230

無限コーティングプレミアム 高硬度用2枚刃ロングネックボールエンドミル

MUGEN COATING PREMIUM 2-Flute Long Neck Ball End Mill for Hardened Steel

レギュラーライン
無限プレミアム
ロングネックタイプ

Regular Line
MUGEN PREMIUM
Long Neck Type

アリハードン鋼 P
Prehardened Steel

ステンレス鋼 M
Stainless Steel

チタン合金
耐熱合金 S
Titanium Alloy
Heat Resistant Alloy

~55 HRC
~65 HRC
高硬度鋼 H
Hardened Steel

コーティング
ロングネック
ボールエンドミル

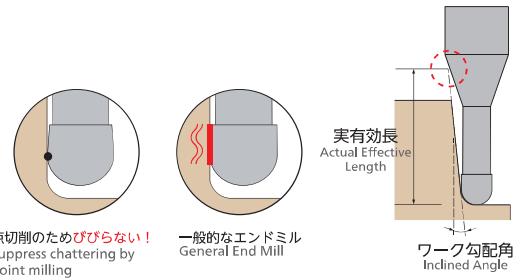

★再研磨可能 (シャンク長15mm以上のもの。詳細はお問い合わせください。)

単位 [寸法 : mm / 価格 : 円]
Unit [Size : mm / Retail Price : JPY]

コードNo. Code No.	(R)ボール半径 Radius	(ℓ ₁)首下長 Under Neck Length	(ℓ)刃長 Length of Cut	(D)外径 Dia.	(d ₂)首下径 Neck Dia.	(γ)首角 Neck Taper Angle	(d)シャンク径 Shank Dia.	(L)全長 Overall Length	標準価格 Retail Price	ワーク勾配角に対する実有効長 Actual effective length depending on inclined angle of workpiece.				
										30'	1°	1°30'	2°	3°
★ 08-00527-01001	R1	3	1.5	2	1.94	12°	4	45	3,200	3.23	3.33	3.44	3.56	3.85
★ 08-00527-01002		4	1.5	2	1.94	12°	4	45	3,200	4.27	4.42	4.58	4.76	5.17
★ 08-00528-01002		4	1.5	2	1.94	12°	6	50	5,100	4.27	4.42	4.58	4.76	5.17
★ 08-00527-01004		6	1.5	2	1.94	12°	4	45	3,600	6.36	6.60	6.86	7.15	7.83
★ 08-00528-01004		6	1.5	2	1.94	12°	6	50	5,500	6.36	6.60	6.86	7.15	7.83
★ 08-00527-01006		8	1.5	2	1.94	12°	4	45	3,900	8.44	8.78	9.14	9.54	10.48
★ 08-00528-01006		8	1.5	2	1.94	12°	6	50	5,900	8.44	8.78	9.14	9.54	10.48
★ 08-00527-01008		10	1.5	2	1.94	12°	4	45	3,900	10.53	10.95	11.42	11.94	13.14
★ 08-00528-01008		10	1.5	2	1.94	12°	6	50	5,900	10.53	10.95	11.42	11.94	13.14
★ 08-00527-01010		12	1.5	2	1.94	12°	4	45	3,900	12.61	13.13	13.70	14.33	15.79
★ 08-00527-01020		13	1.5	2	1.94	12°	4	45	3,900	13.66	14.23	14.86	15.55	17.16
★ 08-00527-01011		14	1.5	2	1.94	12°	4	50	3,900	14.70	15.31	15.98	16.72	18.45
★ 08-00527-01012		16	1.5	2	1.94	12°	4	50	3,900	16.78	17.49	18.27	19.12	Free
★ 08-00528-01012		16	1.5	2	1.94	12°	6	60	5,900	16.78	17.49	18.27	19.12	Free
★ 08-00527-01013		18	1.5	2	1.94	12°	4	55	3,900	18.87	19.67	20.55	21.51	Free
★ 08-00527-01014		20	1.5	2	1.94	12°	4	55	3,900	20.96	21.85	22.83	23.90	Free
★ 08-00527-01015		22	1.5	2	1.94	12°	4	60	5,300	23.04	24.03	25.11	26.30	Free
★ 08-00527-01016		25	1.5	2	1.94	12°	4	65	5,400	26.17	27.30	28.53	29.89	Free
★ 08-00528-01016		25	1.5	2	1.94	12°	6	65	5,500	26.17	27.30	28.53	29.89	Free
★ 08-00527-01017		30	1.5	2	1.94	12°	4	70	6,100	31.38	32.74	34.23	Free	Free
★ 08-00527-01018	35	1.5	2	1.94	12°	4	70	8,300	36.60	38.19	39.93	Free	Free	
★ 08-00527-01019	40	1.5	2	1.94	12°	4	90	8,300	41.81	43.64	Free	Free	Free	
★ 08-00527-01250	R1.25	6	2.3	2.5	2.4	12°	4	45	4,800	6.45	6.68	6.94	7.22	7.89
★ 08-00527-01251		8	2.3	2.5	2.4	12°	4	45	4,200	8.54	8.86	9.22	9.62	10.55
★ 08-00527-01252		10	2.3	2.5	2.4	12°	4	45	5,100	10.62	11.04	11.49	12.00	13.18
★ 08-00527-01253		15	2.3	2.5	2.4	12°	4	50	5,200	15.83	16.48	17.20	17.98	Free
★ 08-00527-01254		20	2.3	2.5	2.4	12°	4	55	6,100	21.04	21.93	22.90	Free	Free
★ 08-00527-01255		25	2.3	2.5	2.4	12°	4	65	6,500	26.26	27.38	28.60	Free	Free
★ 08-00527-01256		30	2.3	2.5	2.4	12°	4	70	7,500	31.47	32.82	Free	Free	Free
★ 08-00527-01257	35	2.3	2.5	2.4	12°	4	70	9,300	36.69	38.27	Free	Free	Free	
★ 08-00527-01501	R1.5	6	2.5	3	2.85	12°	6	60	3,900	6.56	6.78	7.03	7.31	7.95
★ 08-00527-01502		8	2.5	3	2.85	12°	6	60	3,900	8.64	8.96	9.31	9.70	10.60
★ 08-00527-01503		10	2.5	3	2.85	12°	6	60	4,500	10.73	11.14	11.59	12.09	13.26
★ 08-00527-01504		12	2.5	3	2.85	12°	6	60	4,700	12.81	13.32	13.88	14.49	15.91
★ 08-00527-01505		14	2.5	3	2.85	12°	6	60	5,200	14.90	15.50	16.16	16.88	18.57
★ 08-00527-01506		16	2.5	3	2.85	12°	6	60	5,200	16.98	17.68	18.44	19.27	21.22
★ 08-00527-01508		20	2.5	3	2.85	12°	6	65	5,000	21.16	22.04	23.00	24.06	26.53
★ 08-00527-01509		25	2.5	3	2.85	12°	6	65	5,000	26.37	27.48	28.70	30.04	Free
★ 08-00527-01510		30	2.5	3	2.85	12°	6	70	5,700	31.58	32.93	34.40	36.03	Free
★ 08-00527-01511		35	2.5	3	2.85	12°	6	80	7,200	36.80	38.38	40.11	42.01	Free
★ 08-00527-01512		40	2.5	3	2.85	12°	6	90	9,000	42.01	43.83	45.81	Free	Free

オーダー方法
How to Order

MRBH230 ボール半径(R)×首下長(ℓ₁)×シャンク径(d)を指示してください。
When you order, indicate MRBH230 (R)×(ℓ₁)×(d).

※(γ)は参考値です。
※(γ) is reference value.

無限コーティングプレミアム 高硬度用2枚刃ロングネックボールエンドミル

MUGEN COATING PREMIUM 2-Flute Long Neck Ball End Mill for Hardened Steel

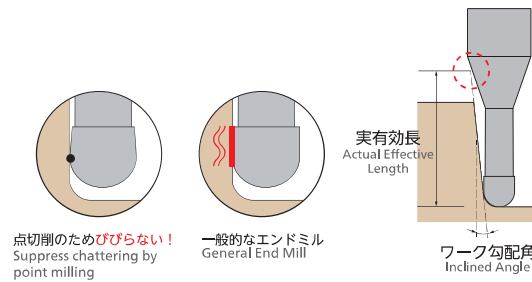

P プリハードン鋼
Prehardened Steel

M ステンレス鋼
Stainless Steel

コードNo. Code No.	(R)ボール半径 Radius	(ℓ ₁)首下長 Under Neck Length	(ℓ)刃長 Length of Cut	(D)外径 Dia.	(d ₂)首下径 Neck Dia.	(γ)首角 Neck Taper Angle	(d)シャンク径 Shank Dia.	(L)全長 Overall Length	標準価格 Retail Price	ワーク勾配角に対する実有効長 Actual effective length depending on inclined angle of workpiece.				
										30°	1°	1°30'	2°	3°
★ 08-00527-01750	R1.75	15	2.8	3.5	3.35	12°	6	60	6,600	15.94	16.58	17.28	18.05	19.86
★ 08-00527-01754		20	2.8	3.5	3.35	12°	6	65	6,600	21.14	22.01	22.96	24.01	Free
★ 08-00527-01751		25	2.8	3.5	3.35	12°	6	65	7,000	26.37	27.47	28.69	30.03	Free
★ 08-00527-01755		30	2.8	3.5	3.35	12°	6	70	7,000	31.57	32.91	34.37	35.98	Free
★ 08-00527-01752		35	2.8	3.5	3.35	12°	6	80	9,000	36.79	38.37	40.10	Free	Free
★ 08-00527-01756		40	2.8	3.5	3.35	12°	6	90	9,000	42.00	43.80	45.77	Free	Free
★ 08-00527-01753		45	2.8	3.5	3.35	12°	6	90	11,000	47.22	49.27	Free	Free	Free
★ 08-00527-02000	R2	8	3	4	3.8	-	4	65	3,800	8.74	9.05	9.38	9.74	10.60
★ 08-00527-02001		8	3	4	3.8	12°	6	65	4,000	8.74	9.05	9.38	9.74	10.60
★ 08-00527-02002		10	3	4	3.8	12°	6	65	4,000	10.83	11.22	11.66	12.14	13.25
★ 08-00527-02003		12	3	4	3.8	12°	6	65	5,200	12.91	13.40	13.94	14.53	15.91
★ 08-00527-02101		14	3	4	3.8	12°	6	65	5,200	15.00	15.58	16.22	16.92	18.56
★ 08-00527-02004		15	3	4	3.8	12°	6	65	5,200	16.04	16.67	17.36	18.12	19.89
★ 08-00527-02006		20	3	4	3.8	12°	6	65	5,200	21.26	22.12	23.06	24.10	Free
★ 08-00527-02008		25	3	4	3.8	12°	6	70	5,200	26.47	27.57	28.77	30.09	Free
★ 08-00527-02010		30	3	4	3.8	12°	6	70	5,200	31.68	33.01	34.47	Free	Free
★ 08-00527-02011		35	3	4	3.8	12°	6	80	6,000	36.90	38.46	40.17	Free	Free
★ 08-00527-02012		40	3	4	3.8	12°	6	85	6,700	42.11	43.91	Free	Free	Free
★ 08-00527-02013		45	3	4	3.8	12°	6	90	8,700	47.33	49.36	Free	Free	Free
★ 08-00527-02014		50	3	4	3.8	12°	6	100	9,500	52.54	54.80	Free	Free	Free
★ 08-00527-02500	R2.5	10	3.5	5	4.8	12°	6	70	6,100	10.81	11.18	11.59	12.04	Free
★ 08-00527-02501		15	3.5	5	4.8	12°	6	70	8,600	16.02	16.63	17.29	Free	Free
★ 08-00527-02502		20	3.5	5	4.8	12°	6	70	8,700	21.24	22.08	Free	Free	Free
★ 08-00527-02503		25	3.5	5	4.8	12°	6	70	8,700	26.45	27.52	Free	Free	Free
★ 08-00527-02504		30	3.5	5	4.8	12°	6	80	9,300	31.66	Free	Free	Free	Free
★ 08-00527-02506		40	3.5	5	4.8	12°	6	90	11,600	42.09	Free	Free	Free	Free
★ 08-00527-03000	R3	10	6	6	5.7	-	6	70	6,500	Free	Free	Free	Free	Free
★ 08-00527-03001		15	6	6	5.7	-	6	70	6,500	Free	Free	Free	Free	Free
★ 08-00527-03002		20	6	6	5.7	-	6	70	6,500	Free	Free	Free	Free	Free
★ 08-00527-03003		25	6	6	5.7	-	6	70	6,500	Free	Free	Free	Free	Free
★ 08-00527-03004		30	6	6	5.7	-	6	80	6,700	Free	Free	Free	Free	Free
★ 08-00527-03007		35	6	6	5.7	-	6	85	6,700	Free	Free	Free	Free	Free
★ 08-00527-03005		40	6	6	5.7	-	6	90	7,300	Free	Free	Free	Free	Free
★ 08-00527-03006		50	6	6	5.7	-	6	120	7,900	Free	Free	Free	Free	Free
★ 08-00527-03008		60	6	6	5.7	-	6	120	8,500	Free	Free	Free	Free	Free

S チタン合金
耐熱合金
Titanium Alloy
Heat Resistant Alloy

H 高硬度鋼
Hardened Steel

~ 55 HRC

~ 65 HRC



MRBH230

切削条件参考表

Recommended Milling Conditions

被削材 Work Material			高硬度鋼 Hardened Steels SKD61・STAVAX・HPM38 (~52HRC)				高硬度鋼 Hardened Steels SKD11 (~62HRC)				ハイス High Speed Steels SKH (~65HRC)			
Rサイズ Radius	首下長 Under Neck Length	外径と 首下長の 比 L/D	切込み量 Depth of Cut		送り速度 Feed	回転数 Spindle Speed	切込み量 Depth of Cut		送り速度 Feed	回転数 Spindle Speed	切込み量 Depth of Cut		送り速度 Feed	回転数 Spindle Speed
			ap mm	ae mm	mm/min	min ⁻¹	ap mm	ae mm	mm/min	min ⁻¹	ap mm	ae mm	mm/min	min ⁻¹
0.05	0.2	2.0	0.003	0.005	120	40,000	0.002	0.005	100	40,000	0.002	0.003	70	40,000
	0.3	3.0	0.003	0.005	100	40,000	0.002	0.005	70	40,000	0.002	0.003	50	40,000
	0.5	5.0	0.002	0.003	70	40,000	0.001	0.003	50	40,000	0.001	0.002	30	40,000
0.075	0.3	2.0	0.003	0.005	180	40,000	0.002	0.005	150	40,000	0.002	0.003	100	40,000
	0.5	3.3	0.003	0.005	150	40,000	0.002	0.005	120	40,000	0.002	0.003	70	40,000
	1	6.7	0.002	0.003	70	40,000	0.001	0.003	50	40,000	0.001	0.002	30	40,000
0.1	0.3	1.5	0.01	0.01	350	40,000	0.006	0.005	300	40,000	0.003	0.003	200	40,000
	0.5	2.5	0.008	0.01	320	40,000	0.005	0.005	280	40,000	0.003	0.003	180	40,000
	0.75	3.8	0.005	0.01	280	40,000	0.003	0.005	200	40,000	0.002	0.003	150	40,000
	1	5.0	0.003	0.005	250	40,000	0.002	0.003	160	40,000	0.001	0.002	120	40,000
	1.25	6.3	0.003	0.005	180	40,000	0.002	0.003	140	40,000	0.001	0.002	100	40,000
	1.5	7.5	0.003	0.005	150	40,000	0.002	0.003	120	40,000	0.001	0.002	80	40,000
	1.75	8.8	0.002	0.003	120	40,000	0.001	0.002	100	40,000	0.001	0.002	60	40,000
	2	10.0	0.002	0.003	100	40,000	0.001	0.002	80	40,000	0.001	0.001	50	40,000
	2.5	12.5	0.001	0.002	70	40,000	0.001	0.001	60	40,000	0.001	0.001	40	40,000
0.15	0.5	1.7	0.01	0.015	350	40,000	0.007	0.01	300	40,000	0.003	0.005	280	40,000
	0.6	2.0	0.007	0.01	350	40,000	0.005	0.007	300	40,000	0.003	0.005	250	40,000
	0.75	2.5	0.007	0.01	330	40,000	0.005	0.007	280	40,000	0.003	0.005	230	40,000
	1	3.3	0.007	0.01	320	40,000	0.005	0.007	250	40,000	0.003	0.005	200	40,000
	1.25	4.2	0.005	0.007	280	40,000	0.003	0.005	200	40,000	0.002	0.003	160	40,000
	1.5	5.0	0.005	0.007	230	40,000	0.003	0.005	180	40,000	0.002	0.003	120	40,000
	1.75	5.8	0.003	0.005	180	40,000	0.002	0.003	150	40,000	0.002	0.002	100	40,000
	2	6.7	0.003	0.005	150	40,000	0.002	0.003	120	40,000	0.002	0.002	90	40,000
	2.25	7.5	0.002	0.003	120	40,000	0.001	0.002	100	40,000	0.001	0.001	80	40,000
	2.5	8.3	0.002	0.003	100	40,000	0.001	0.002	80	40,000	0.001	0.001	70	40,000
	3	10.0	0.001	0.003	80	40,000	0.001	0.002	70	40,000	0.001	0.001	60	40,000
	3.5	11.7	0.001	0.002	70	40,000	0.001	0.001	60	40,000	0.001	0.001	50	40,000
0.2	0.5	1.3	0.03	0.05	800	40,000	0.03	0.03	720	40,000	0.009	0.02	580	40,000
	0.8	2.0	0.02	0.05	800	40,000	0.02	0.03	720	40,000	0.008	0.02	580	40,000
	1	2.5	0.02	0.05	800	40,000	0.02	0.03	720	40,000	0.008	0.02	580	40,000
	1.5	3.8	0.01	0.03	620	40,000	0.01	0.02	500	40,000	0.005	0.01	400	40,000
	2	5.0	0.01	0.02	500	40,000	0.01	0.01	380	40,000	0.005	0.007	300	40,000
	2.5	6.3	0.007	0.01	420	40,000	0.005	0.007	300	40,000	0.003	0.005	260	40,000
	3	7.5	0.007	0.01	300	40,000	0.005	0.007	240	40,000	0.003	0.005	200	40,000
	3.5	8.8	0.005	0.007	230	40,000	0.003	0.005	160	40,000	0.002	0.003	120	40,000
	4	10.0	0.005	0.005	160	30,000	0.003	0.003	120	30,000	0.002	0.003	90	30,000
	4.5	11.3	0.003	0.005	100	30,000	0.002	0.003	80	30,000	0.001	0.002	60	30,000
	5	12.5	0.002	0.003	70	30,000	0.001	0.002	50	30,000	0.001	0.002	40	30,000
	6	15.0	0.001	0.002	50	30,000	0.001	0.001	40	30,000	0.001	0.001	30	30,000
0.25	1	2.0	0.03	0.05	1,000	40,000	0.02	0.03	860	40,000	0.01	0.02	650	40,000
	1.5	3.0	0.02	0.05	850	40,000	0.01	0.03	720	40,000	0.007	0.02	520	40,000
	2	4.0	0.02	0.03	720	40,000	0.01	0.02	650	40,000	0.007	0.01	400	40,000
	2.5	5.0	0.01	0.02	600	40,000	0.007	0.01	530	40,000	0.005	0.007	360	40,000
	3	6.0	0.01	0.02	500	40,000	0.007	0.01	420	40,000	0.005	0.007	320	40,000
	3.5	7.0	0.007	0.01	420	40,000	0.005	0.007	360	40,000	0.003	0.005	280	40,000
	4	8.0	0.007	0.01	350	40,000	0.005	0.007	300	40,000	0.003	0.005	260	40,000
	4.5	9.0	0.005	0.005	300	40,000	0.003	0.003	260	40,000	0.002	0.003	220	40,000
	5	10.0	0.005	0.005	240	33,000	0.003	0.003	200	33,000	0.002	0.003	180	33,000
	5.5	11.0	0.003	0.005	200	30,000	0.002	0.003	160	30,000	0.001	0.002	120	30,000
	6	12.0	0.002	0.003	120	30,000	0.001	0.002	80	30,000	0.001	0.002	70	30,000
	8	16.0	0.002	0.002	75	30,000	0.001	0.002	60	30,000	0.001	0.002	50	30,000
10	20.0	0.001	0.002	40	20,000	0.001	0.002	30	20,000	0.001	0.001	20	20,000	

○ プリハードン鋼 P
Prehardened Steel

○ ステンレス鋼 M
Stainless Steel

○ チタン合金 S
耐熱合金
Titanium Alloy
Heat Resistant Alloy

○ ~55 HRC
○ ~65 HRC
H
高硬度鋼
Hardened Steel

Coating
コーティング
ロングネック
Long Neck
ロングネック
Long Neck

切削条件参考表

Recommended Milling Conditions

被削材 Work Material			高硬度鋼 Hardened Steels SKD61・STAVAX・HPM38(～52HRC)				高硬度鋼 Hardened Steels SKD11(～62HRC)				ハイス High Speed Steels SKH(～65HRC)			
Rサイズ Radius	首下長 Under Neck Length	外径と 首下長 の比 L/D	切込み量 Depth of Cut		送り速度 Feed	回転数 Spindle Speed	切込み量 Depth of Cut		送り速度 Feed	回転数 Spindle Speed	切込み量 Depth of Cut		送り速度 Feed	回転数 Spindle Speed
			ap mm	ae mm	mm/min	min ⁻¹	ap mm	ae mm	mm/min	min ⁻¹	ap mm	ae mm	mm/min	min ⁻¹
0.3	1	1.7	0.05	0.1	1,400	40,000	0.03	0.06	1,000	40,000	0.02	0.05	720	30,000
	1.5	2.5	0.05	0.1	1,400	40,000	0.03	0.06	1,000	40,000	0.02	0.05	720	30,000
	2	3.3	0.05	0.1	1,400	40,000	0.03	0.06	1,000	40,000	0.02	0.05	720	30,000
	2.5	4.2	0.03	0.05	1,200	40,000	0.02	0.04	840	40,000	0.02	0.03	640	30,000
	3	5.0	0.03	0.05	1,200	40,000	0.02	0.04	840	40,000	0.02	0.03	640	30,000
	3.5	5.8	0.02	0.03	1,000	40,000	0.01	0.03	620	40,000	0.01	0.02	480	30,000
	4	6.7	0.02	0.03	1,000	40,000	0.01	0.03	620	40,000	0.01	0.02	480	30,000
	4.5	7.5	0.02	0.03	900	35,000	0.01	0.02	580	35,000	0.008	0.015	430	30,000
	5	8.3	0.01	0.02	720	30,000	0.007	0.015	500	30,000	0.007	0.01	400	30,000
	5.5	9.2	0.01	0.015	700	30,000	0.007	0.01	450	30,000	0.005	0.008	360	30,000
	6	10.0	0.007	0.01	500	30,000	0.005	0.007	380	30,000	0.004	0.006	320	30,000
	7	11.7	0.005	0.007	400	25,000	0.003	0.005	300	25,000	0.003	0.003	260	20,000
8	13.3	0.003	0.005	320	25,000	0.003	0.003	260	25,000	0.002	0.003	220	20,000	
9	15.0	0.003	0.003	280	25,000	0.003	0.002	220	25,000	0.001	0.002	160	20,000	
10	16.7	0.002	0.003	150	20,000	0.002	0.002	120	20,000	0.001	0.002	100	18,000	
12	20.0	0.002	0.002	80	20,000	0.002	0.002	60	20,000	0.001	0.002	50	18,000	
0.35	2	2.9	0.07	0.1	1,600	40,000	0.05	0.08	1,300	40,000	0.03	0.07	1,000	30,000
	4	5.7	0.04	0.06	1,300	40,000	0.03	0.04	820	40,000	0.015	0.02	600	30,000
	6	8.6	0.01	0.03	800	30,000	0.01	0.015	500	30,000	0.006	0.01	420	25,000
	8	11.4	0.006	0.01	520	25,000	0.005	0.006	380	20,000	0.004	0.006	250	20,000
0.4	2	2.5	0.1	0.15	2,000	40,000	0.07	0.1	1,600	40,000	0.05	0.1	1,200	30,000
	3	3.8	0.1	0.15	2,000	40,000	0.07	0.1	1,600	40,000	0.05	0.05	1,200	30,000
	4	5.0	0.05	0.1	1,600	40,000	0.05	0.05	1,200	40,000	0.03	0.05	860	30,000
	5	6.3	0.05	0.05	1,600	40,000	0.03	0.05	1,000	40,000	0.02	0.03	620	30,000
	6	7.5	0.03	0.05	1,200	30,000	0.02	0.03	760	30,000	0.01	0.02	560	25,000
	7	8.8	0.02	0.03	1,000	30,000	0.01	0.02	680	30,000	0.007	0.01	520	25,000
	8	10.0	0.01	0.02	820	30,000	0.007	0.01	600	30,000	0.005	0.01	480	25,000
	10	12.5	0.005	0.005	450	25,000	0.003	0.003	380	25,000	0.002	0.003	320	20,000
12	15.0	0.003	0.005	320	20,000	0.002	0.003	260	20,000	0.002	0.002	200	20,000	
0.45	2	2.2	0.1	0.2	2,200	40,000	0.08	0.15	1,800	30,000	0.06	0.1	1,300	30,000
	4	4.4	0.05	0.12	1,800	40,000	0.04	0.08	1,400	30,000	0.03	0.05	900	25,000
	6	6.7	0.035	0.05	1,200	30,000	0.025	0.035	800	25,000	0.015	0.025	600	20,000
	8	8.9	0.025	0.04	1,000	30,000	0.015	0.025	700	23,000	0.008	0.015	500	20,000
0.5	2	2.0	0.1	0.3	2,500	40,000	0.1	0.2	2,000	30,000	0.08	0.1	1,400	25,000
	2.5	2.5	0.1	0.3	2,500	40,000	0.1	0.2	2,000	30,000	0.08	0.1	1,400	25,000
	3	3.0	0.1	0.3	2,500	40,000	0.1	0.2	2,000	30,000	0.08	0.1	1,400	25,000
	4	4.0	0.1	0.2	2,500	40,000	0.05	0.15	1,800	30,000	0.05	0.1	1,200	25,000
	5	5.0	0.05	0.15	2,000	30,000	0.04	0.1	1,600	25,000	0.03	0.05	920	20,000
	6	6.0	0.05	0.1	1,800	30,000	0.04	0.05	1,200	25,000	0.02	0.05	740	20,000
	7	7.0	0.04	0.06	1,200	30,000	0.03	0.04	950	25,000	0.02	0.03	680	20,000
	8	8.0	0.04	0.06	1,000	30,000	0.03	0.04	860	25,000	0.02	0.03	560	20,000
	9	9.0	0.03	0.05	820	25,000	0.02	0.03	750	20,000	0.01	0.02	500	18,000
	10	10.0	0.03	0.05	750	25,000	0.02	0.03	620	20,000	0.01	0.02	450	18,000
	12	12.0	0.01	0.03	600	20,000	0.007	0.02	520	18,000	0.005	0.01	400	16,000
	13	13.0	0.008	0.02	500	20,000	0.005	0.01	420	18,000	0.003	0.006	350	16,000
	14	14.0	0.005	0.01	420	20,000	0.003	0.007	360	18,000	0.002	0.005	320	16,000
	16	16.0	0.005	0.005	300	18,000	0.003	0.005	250	16,000	0.002	0.003	200	14,000
18	18.0	0.003	0.005	180	18,000	0.002	0.005	120	16,000	0.002	0.002	85	14,000	
20	20.0	0.003	0.003	100	16,000	0.002	0.003	75	14,000	0.002	0.002	60	12,000	
22	22.0	0.002	0.003	50	14,000	0.002	0.002	40	12,000	0.001	0.002	35	10,000	

P プリハードン鋼
Prehardened SteelM ステンレス鋼
Stainless SteelS チタン合金
耐熱合金
Titanium Alloy
Heat Resistant AlloyH 高硬度鋼
Hardened Steel
～55 HRC
～65 HRCコーティング
Coating
ロングネック
Long Neck
ボール
Ball

MRBH230

切削条件参考表

Recommended Milling Conditions

被削材 Work Material			高硬度鋼 Hardened Steels SKD61・STAVAX・HPM38 (~52HRC)				高硬度鋼 Hardened Steels SKD11 (~62HRC)				ハイス High Speed Steels SKH (~65HRC)				
Rサイズ Radius	首下長 Under Neck Length	外径と 首下長の 比 L/D	切込み量 Depth of Cut		送り速度 Feed	回転数 Spindle Speed	切込み量 Depth of Cut		送り速度 Feed	回転数 Spindle Speed	切込み量 Depth of Cut		送り速度 Feed	回転数 Spindle Speed	
			ap mm	ae mm	mm/min	min ⁻¹	ap mm	ae mm	mm/min	min ⁻¹	ap mm	ae mm	mm/min	min ⁻¹	
0.6	2.4	2.0	0.1	0.3	2,500	30,000	0.1	0.2	2,000	30,000	0.05	0.1	1,600	25,000	
	4	3.3	0.1	0.2	2,500	30,000	0.07	0.2	2,000	30,000	0.05	0.1	1,600	25,000	
	6	5.0	0.07	0.1	2,000	30,000	0.05	0.1	1,600	25,000	0.03	0.07	1,200	20,000	
	8	6.7	0.05	0.1	1,600	30,000	0.03	0.07	1,200	25,000	0.02	0.05	920	20,000	
	10	8.3	0.03	0.07	1,200	20,000	0.02	0.05	860	20,000	0.01	0.03	680	18,000	
	12	10.0	0.02	0.05	860	20,000	0.01	0.03	620	20,000	0.007	0.02	480	18,000	
	14	11.7	0.02	0.03	600	18,000	0.01	0.02	400	18,000	0.005	0.01	300	16,000	
0.7	16	13.3	0.01	0.02	350	16,000	0.005	0.01	250	16,000	0.003	0.007	130	14,000	
	8	5.7	0.12	0.2	2,500	30,000	0.08	0.15	1,800	20,000	0.03	0.08	1,000	20,000	
	12	8.6	0.07	0.12	1,400	20,000	0.04	0.08	1,100	18,000	0.015	0.05	700	18,000	
0.75	16	11.4	0.02	0.05	700	17,000	0.01	0.03	600	17,000	0.008	0.02	450	16,000	
	3	2.0	0.15	0.3	3,000	30,000	0.1	0.3	2,500	30,000	0.1	0.2	2,000	25,000	
	4	2.7	0.15	0.3	3,000	30,000	0.1	0.3	2,500	30,000	0.1	0.2	2,000	25,000	
	6	4.0	0.15	0.2	3,000	30,000	0.1	0.2	2,000	30,000	0.1	0.1	1,600	25,000	
	8	5.3	0.1	0.2	2,500	25,000	0.05	0.2	1,600	25,000	0.05	0.1	1,200	20,000	
	10	6.7	0.1	0.1	2,500	25,000	0.05	0.1	1,200	25,000	0.05	0.05	860	20,000	
	12	8.0	0.05	0.1	1,800	20,000	0.03	0.1	920	20,000	0.02	0.05	780	18,000	
	14	9.3	0.05	0.07	1,200	20,000	0.03	0.05	820	20,000	0.02	0.03	650	18,000	
	16	10.7	0.03	0.05	720	18,000	0.02	0.03	650	18,000	0.01	0.02	580	16,000	
	18	12.0	0.02	0.04	550	16,000	0.012	0.025	400	16,000	0.008	0.015	400	14,000	
0.8	20	13.3	0.01	0.03	450	16,000	0.01	0.02	360	16,000	0.007	0.01	300	14,000	
	22	14.7	0.01	0.02	330	14,000	0.01	0.01	250	14,000	0.007	0.007	200	12,000	
	30	20.0	0.005	0.005	80	10,000	0.003	0.005	60	10,000	0.003	0.003	40	8,000	
	8	5.0	0.1	0.2	2,500	25,000	0.07	0.15	2,000	20,000	0.05	0.1	1,600	18,000	
	12	7.5	0.07	0.1	1,800	20,000	0.05	0.07	1,500	16,000	0.03	0.05	1,200	14,000	
	16	10.0	0.03	0.05	720	16,000	0.02	0.03	600	14,000	0.015	0.02	480	12,000	
	20	12.5	0.01	0.03	500	14,000	0.01	0.02	380	12,000	0.01	0.01	300	10,000	
	1	3	1.5	0.2	0.5	3,000	25,000	0.2	0.5	2,500	25,000	0.15	0.3	2,000	20,000
		4	2.0	0.2	0.5	3,000	25,000	0.2	0.5	2,500	25,000	0.15	0.3	2,000	20,000
		6	3.0	0.2	0.5	2,500	25,000	0.2	0.3	2,000	25,000	0.15	0.3	1,600	20,000
8		4.0	0.2	0.3	2,000	20,000	0.1	0.2	1,600	18,000	0.1	0.2	1,200	16,000	
10		5.0	0.1	0.3	2,000	18,000	0.1	0.2	1,600	16,000	0.1	0.1	1,200	14,000	
12		6.0	0.1	0.2	1,600	16,000	0.1	0.1	1,200	14,000	0.05	0.1	940	12,000	
13		6.5	0.08	0.2	1,600	16,000	0.06	0.1	1,200	14,000	0.04	0.08	940	12,000	
14		7.0	0.07	0.15	1,600	16,000	0.05	0.08	1,200	14,000	0.03	0.07	940	12,000	
16		8.0	0.07	0.15	1,600	16,000	0.05	0.08	1,200	14,000	0.03	0.07	940	12,000	
18		9.0	0.05	0.1	1,400	14,000	0.03	0.05	1,000	12,000	0.02	0.03	850	10,000	
20		10.0	0.05	0.1	1,000	14,000	0.03	0.05	820	12,000	0.02	0.03	720	10,000	
22		11.0	0.03	0.08	850	14,000	0.02	0.06	700	12,000	0.02	0.02	600	10,000	
25		12.5	0.03	0.05	680	12,000	0.02	0.03	560	10,000	0.01	0.02	420	8,500	
30		15.0	0.02	0.03	360	12,000	0.01	0.02	300	10,000	0.008	0.01	240	8,500	
35		17.5	0.01	0.02	150	10,000	0.007	0.01	120	8,000	0.005	0.007	100	6,800	
40		20.0	0.005	0.01	100	10,000	0.003	0.005	80	8,000	0.002	0.003	50	6,800	
1.25		6	2.4	0.3	0.4	2,800	20,000	0.2	0.5	2,300	20,000	0.15	0.4	2,000	18,000
	8	3.2	0.25	0.3	2,600	20,000	0.15	0.3	2,100	20,000	0.12	0.25	1,800	18,000	
	10	4.0	0.2	0.3	2,500	20,000	0.15	0.2	2,000	20,000	0.1	0.15	1,600	18,000	
	15	6.0	0.1	0.2	2,000	18,000	0.07	0.15	1,600	16,000	0.05	0.1	1,200	14,000	
	20	8.0	0.07	0.15	1,500	16,000	0.05	0.1	1,200	14,000	0.03	0.05	1,000	10,000	
	25	10.0	0.05	0.1	1,000	14,000	0.03	0.07	850	12,000	0.02	0.03	720	8,000	
	30	12.0	0.03	0.07	720	12,000	0.02	0.05	640	10,000	0.01	0.02	580	7,000	
35	14.0	0.02	0.03	450	10,000	0.01	0.02	400	8,500	0.007	0.01	320	6,200		

プリハードン鋼 P
Prehardened Steel

ステンレス鋼 M
Stainless Steel

チタン合金 S
耐熱合金
Titanium Alloy
Heat Resistant Alloy

高硬度鋼 H
~55 HRC
~65 HRC
Hardened Steel

コーティング
Coating
ロングネック
Long Neck
ロングネック
Long Neck

切削条件参考表

Recommended Milling Conditions

被削材 Work Material			高硬度鋼 Hardened Steels SKD61・STAVAX・HPM38(～52HRC)				高硬度鋼 Hardened Steels SKD11(～62HRC)				ハイス High Speed Steels SKH(～65HRC)			
Rサイズ Radius	首下長 Under Neck Length	外径と 首下長の比 L/D	切込み量 Depth of Cut		送り速度 Feed	回転数 Spindle Speed	切込み量 Depth of Cut		送り速度 Feed	回転数 Spindle Speed	切込み量 Depth of Cut		送り速度 Feed	回転数 Spindle Speed
			a _p mm	a _e mm	mm/min	min ⁻¹	a _p mm	a _e mm	mm/min	min ⁻¹	a _p mm	a _e mm	mm/min	min ⁻¹
1.5	6	2.0	0.2	0.8	3,000	20,000	0.2	0.6	2,500	18,000	0.2	0.5	2,000	14,000
	8	2.7	0.2	0.8	3,000	20,000	0.2	0.6	2,500	18,000	0.2	0.5	2,000	14,000
	10	3.3	0.2	0.6	2,500	20,000	0.2	0.4	2,000	18,000	0.1	0.3	1,500	14,000
	12	4.0	0.2	0.6	2,500	20,000	0.2	0.4	2,000	18,000	0.1	0.3	1,500	14,000
	14	4.7	0.1	0.4	2,000	18,000	0.1	0.3	1,600	16,000	0.1	0.2	1,200	12,000
	16	5.3	0.1	0.4	2,000	18,000	0.1	0.3	1,600	16,000	0.1	0.2	1,200	12,000
	20	6.7	0.1	0.3	1,600	18,000	0.1	0.2	1,200	16,000	0.1	0.1	960	12,000
	25	8.3	0.1	0.2	1,200	16,000	0.07	0.15	920	14,000	0.05	0.07	800	10,000
	30	10.0	0.07	0.1	750	14,000	0.05	0.07	640	12,000	0.03	0.05	600	8,600
	35	11.7	0.05	0.1	620	12,000	0.03	0.07	500	10,000	0.02	0.05	420	7,200
40	13.3	0.03	0.07	450	10,000	0.02	0.05	320	8,200	0.01	0.03	260	6,400	
1.75	15	4.3	0.25	1	3,000	20,000	0.15	0.5	2,300	16,000	0.13	0.4	1,500	14,000
	20	5.7	0.18	0.6	2,500	18,000	0.1	0.3	1,800	15,000	0.1	0.2	1,200	12,000
	25	7.1	0.12	0.35	1,800	16,000	0.1	0.2	1,600	14,000	0.06	0.12	1,000	10,000
	30	8.6	0.1	0.25	1,500	14,000	0.07	0.15	950	11,000	0.05	0.08	800	9,000
	35	10.0	0.08	0.2	1,200	13,000	0.07	0.12	800	10,000	0.03	0.06	650	7,500
40	11.4	0.07	0.1	800	11,000	0.04	0.07	720	9,000	0.02	0.05	450	7,000	
45	12.9	0.06	0.07	700	10,000	0.035	0.05	600	7,500	0.015	0.03	320	6,000	
2	8	2.0	0.3	1.5	3,000	20,000	0.2	0.8	2,500	16,000	0.2	0.6	2,000	12,000
	10	2.5	0.3	1.5	3,000	20,000	0.2	0.8	2,500	16,000	0.2	0.6	2,000	12,000
	12	3.0	0.3	1.5	3,000	20,000	0.2	0.8	2,500	16,000	0.2	0.6	2,000	12,000
	14	3.5	0.3	1.5	3,000	20,000	0.2	0.8	2,000	16,000	0.2	0.6	1,600	12,000
	15	3.8	0.3	1.5	3,000	20,000	0.2	0.8	2,000	16,000	0.2	0.6	1,600	12,000
	20	5.0	0.2	1	2,400	16,000	0.1	0.6	1,800	14,000	0.1	0.4	1,400	10,000
	25	6.3	0.2	0.8	1,600	16,000	0.1	0.4	1,200	14,000	0.1	0.2	1,000	10,000
	30	7.5	0.1	0.3	1,600	14,000	0.07	0.2	1,200	10,000	0.05	0.15	1,000	8,200
	35	8.8	0.1	0.2	1,200	14,000	0.07	0.15	1,000	10,000	0.05	0.1	820	8,200
	40	10.0	0.07	0.15	1,200	12,000	0.05	0.1	1,000	8,600	0.03	0.07	820	6,800
45	11.3	0.07	0.1	750	12,000	0.05	0.07	620	8,600	0.03	0.05	500	6,800	
50	12.5	0.05	0.08	550	10,000	0.03	0.05	500	7,500	0.02	0.03	420	5,500	
2.5	10	2.0	0.3	1.5	3,000	18,000	0.2	1.2	2,500	12,000	0.2	0.7	2,000	9,200
	15	3.0	0.3	1.5	3,000	18,000	0.2	1.2	2,500	12,000	0.2	0.7	2,000	9,200
	20	4.0	0.3	1.2	3,000	15,000	0.2	1	2,000	10,000	0.15	0.5	1,600	8,000
	25	5.0	0.2	1	2,500	15,000	0.15	0.8	1,800	8,600	0.1	0.3	1,200	7,200
	30	6.0	0.2	0.8	2,000	12,000	0.15	0.5	1,500	7,600	0.1	0.2	860	6,400
40	8.0	0.1	0.2	1,200	10,000	0.07	0.15	1,000	6,800	0.05	0.1	650	5,500	
3	10	1.7	0.3	2	3,000	16,000	0.3	1.2	2,500	8,000	0.2	1	2,000	7,000
	15	2.5	0.3	2	3,000	16,000	0.3	1.2	2,500	8,000	0.2	1	2,000	7,000
	20	3.3	0.3	2	3,000	16,000	0.3	1.2	2,500	8,000	0.2	1	2,000	7,000
	25	4.2	0.3	1.5	3,000	16,000	0.2	1	2,000	8,000	0.15	0.7	1,500	7,000
	30	5.0	0.2	1.5	3,000	14,000	0.2	1	2,000	7,200	0.15	0.7	1,500	6,500
	35	5.8	0.2	1.2	2,400	13,000	0.17	0.8	1,600	6,800	0.12	0.5	1,200	5,800
	40	6.7	0.2	1	1,800	12,000	0.15	0.6	1,200	6,400	0.1	0.4	1,000	5,200
	50	8.3	0.1	0.6	1,200	8,200	0.1	0.3	860	4,800	0.05	0.2	620	4,000
60	10.0	0.07	0.3	600	6,000	0.05	0.15	450	3,200	0.03	0.07	300	2,500	

備考
Notes

- ※1 切込み量の、a_pは軸方向の切込み深さ、a_eはピックフィードを示します。
 ※2 オイルミストクーラントをお奨めします。
 ※3 回転数と送り速度は、同じ割合で調整してください。
 ※4 切込み量、機械剛性により条件が異なることがあります。その都度調整してください。
 ※5 工具突き出し量は、必要以上に出さないでください。
 ※1 Depth of Cut: a_p=Axial Depth of Cut / a_e=Radial Depth of Cut.
 ※2 We recommend using oil mist coolant.
 ※3 Adjust both spindle speed and feed at the same rate.
 ※4 Adjust milling conditions according to the volume of depth of cut and rigidity of machine.
 ※5 Length of tool overhang must be as short as possible.

P プリハードン鋼
Prehardened SteelM ステンレス鋼
Stainless SteelS チタン合金
耐熱合金
Titanium Alloy
Heat Resistant AlloyH 高硬度鋼
Hardened Steel
～55 HRC
～65 HRCロングネック
Long Neck
コーティング
Coating

MACH225

サイズ
Size R0.1 ~ R3

∞ Premium ≤ 65 HRC

無限コーティングプレミアム 高速・高硬度加工用ボールエンドミル

MUGEN COATING PREMIUM 2-Flute Ball End Mill with Short Shank for Hardened Steel

鋭い刃先で切削負荷を軽減し靱性の高い被削材に対応

Sharp cutting edge reduces cutting load for tough materials

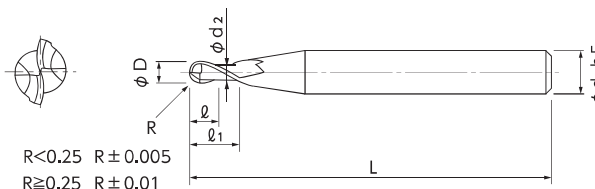

- 高速・高硬度鋼加工用に設計されたボールエンドミル。
- 切込みを多く設定でき、高速送りで効果を発揮。
- ■の規格・サイズは特定商社在庫となります。詳しくはお問い合わせください。
- It is designed for high speed cutting of hardened steels.
- Perform efficiently under high feed condition and able to take large depth of cut.
- ■ : Semi-standard item, please inquire for price and delivery.

単位 [寸法 : mm / 価格 : 円]
Unit [Size : mm / Retail Price : JPY]

コードNo. Code No.	(R)ボール半径 Radius	(ℓ ₁)首下長 Under Neck Length	(ℓ)刃長 Length of Cut	(D)外径 Dia.	(d ₂)首下径 Neck Dia.	(d)シャンク径 Shank Dia.	(L)全長 Overall Length	標準価格 Retail Price	ワーク勾配角に対する実有効長 Actual effective length depending on inclined angle of workpiece.				
									30°	1°	1°30'	2°	3°
08-00555-01011	R0.1	0.5	0.2	0.2	0.175	4	50	10,000	0.57	0.60	0.62	0.64	0.71
08-00555-01012		0.5	0.2	0.2	0.175	6	50	12,500	0.57	0.60	0.62	0.64	0.71
08-00555-02011	R0.2	1	0.4	0.4	0.365	4	50	9,000	1.12	1.16	1.20	1.25	1.37
08-00555-02012		1	0.4	0.4	0.365	6	50	11,500	1.12	1.16	1.20	1.25	1.37
08-00555-02511	R0.25	1.25	0.5	0.5	0.46	4	50	8,000	1.39	1.44	1.49	1.56	1.70
08-00555-02512		1.25	0.5	0.5	0.46	6	50	10,500	1.39	1.44	1.49	1.56	1.70
08-00555-03011	R0.3	1.5	0.6	0.6	0.56	4	50	7,000	1.65	1.71	1.77	1.85	2.02
08-00555-03012		1.5	0.6	0.6	0.56	6	50	9,500	1.65	1.71	1.77	1.85	2.02
08-00555-04011	R0.4	2	0.8	0.8	0.76	4	50	6,500	2.16	2.24	2.33	2.42	2.65
08-00555-04012		2	0.8	0.8	0.76	6	50	9,000	2.16	2.24	2.33	2.42	2.65
08-00555-05011	R0.5	2.5	1	1	0.95	4	50	5,800	3.51	3.78	4.02	4.26	4.70
08-00555-05012		2.5	1	1	0.95	6	50	8,300	3.51	3.78	4.02	4.26	4.70
08-00555-05021		4	1	1	0.95	6	50	12,500 ■	5.14	5.49	5.80	6.08	6.60
08-00555-05022		6	1	1	0.95	6	50	13,200 ■	7.29	7.73	8.10	8.44	9.04
08-00555-07511	R0.75	3.8	1.5	1.5	1.45	4	50	5,800	4.90	5.23	5.52	5.79	6.29
08-00555-07512		3.8	1.5	1.5	1.45	6	50	8,300	4.90	5.23	5.52	5.79	6.29
08-00555-10011	R1	5	2	2	1.94	4	50	5,200	6.22	6.59	6.91	7.21	7.74
08-00555-10012		5	2	2	1.94	6	50	8,300	6.22	6.59	6.91	7.21	7.74
08-00555-10022		6	2	2	1.94	6	50	14,500 ■	7.30	7.71	8.06	8.38	8.96
08-00555-10032		8	2	2	1.94	6	50	15,400 ■	9.43	9.91	10.32	10.69	11.33
08-00555-15012	R1.5	8	3	3	2.85	6	60	9,100	8.88	9.33	9.85	10.45	11.94
08-00555-15022		10	3	3	2.85	6	60	15,000 ■	10.99	11.58	12.25	13.01	14.93
08-00555-15032		15	3	3	2.85	6	60	16,200 ■	16.28	17.20	18.24	19.43	22.40
08-00555-20012	R2	10	4	4	3.8	6	60	9,100	11.13	11.70	12.34	13.08	14.92
08-00555-25012	R2.5	12	5	5	4.8	6	60	10,000	13.22	13.88	14.64	15.50	Free
08-00555-30012	R3	15	6	6	5.7	6	60	10,000	Free	Free	Free	Free	Free

オーダー方法
How to Order

MACH225 ボール半径 (R) × 首下長 (ℓ₁) × シャンク径 (d) を指示してください。
When you order, indicate MACH225 (R)×(ℓ₁)×(d).

※(γ)は参考値です。
※(γ) is reference value.

アリハードン鋼 P
Prehardened Steel

ステンレス鋼 M
Stainless Steel

チタン合金 S
耐熱合金
Titanium Alloy
Heat Resistant Alloy

~55 HRC
~65 HRC
高硬度鋼 H
Hardened Steel

コーティング
Long neck
ロングネック
ボールエンドミル

切削条件参考表 Recommended Milling Conditions

被削材 Work Material	炭素鋼・調質鋼 Carbon Steels・Prehardened Steels S50C・HPM・NAK (~43HRC)					高硬度鋼 Hardened Steels SKD61・STAVAX・HPM38 (~55HRC)					高硬度鋼 Hardened Steels SKD11 (~62HRC)				
	通常条件 Normal Speed		高速条件 High Speed		切込み量 Depth of Cut	通常条件 Normal Speed		高速条件 High Speed		切込み量 Depth of Cut	通常条件 Normal Speed		高速条件 High Speed		切込み量 Depth of Cut
	回転数 Spindle Speed	送り速度 Feed	回転数 Spindle Speed	送り速度 Feed		ap×ae	回転数 Spindle Speed	送り速度 Feed	回転数 Spindle Speed		送り速度 Feed	ap×ae	回転数 Spindle Speed	送り速度 Feed	
Rサイズ Radius	min ⁻¹	mm/min	min ⁻¹	mm/min	mm	min ⁻¹	mm/min	min ⁻¹	mm/min	mm	min ⁻¹	mm/min	min ⁻¹	mm/min	mm
0.1	20,000	400	50,000	800	0.01×0.02	20,000	250	50,000	500	0.01×0.02	20,000	250	50,000	500	0.01×0.02
0.2	20,000	600	50,000	1,000	0.02×0.05	20,000	320	50,000	680	0.02×0.05	20,000	320	50,000	680	0.02×0.05
0.25	20,000	800	50,000	1,200	0.03×0.05	20,000	400	50,000	800	0.02×0.05	20,000	400	50,000	800	0.02×0.05
0.3	20,000	1,200	50,000	2,000	0.05×0.1	20,000	460	50,000	1,000	0.03×0.05	20,000	460	50,000	1,000	0.03×0.05
0.4	20,000	1,600	50,000	2,500	0.1×0.2	20,000	580	50,000	1,200	0.05×0.1	20,000	580	50,000	1,200	0.05×0.1
0.5	20,000	2,000	50,000	5,000	0.2×0.3	20,000	1,200	50,000	3,000	0.1×0.2	20,000	800	50,000	2,000	0.1×0.2
0.75	20,000	2,000	50,000	5,000	0.2×0.3	20,000	1,600	42,000	3,000	0.1×0.2	20,000	1,200	32,000	2,000	0.1×0.2
1	20,000	3,200	50,000	8,000	0.3×0.5	20,000	2,500	32,000	3,500	0.2×0.5	20,000	2,000	24,000	2,400	0.2×0.5
1.5	16,000	2,800	32,000	6,000	0.3×0.5	16,000	2,500	21,000	3,500	0.2×0.5	13,000	2,000	16,000	2,400	0.2×0.5
2	12,000	2,400	24,000	5,000	0.5×1	12,000	2,000	16,000	3,000	0.2×0.7	9,600	1,600	12,000	2,000	0.2×0.7
2.5	9,600	2,000	20,000	5,000	0.5×1	9,600	2,000	13,000	3,000	0.2×0.7	7,600	1,300	9,600	1,600	0.2×0.7
3	8,000	2,000	16,000	4,000	0.5×1.5	8,000	1,600	10,000	2,500	0.2×1	6,400	1,000	8,000	1,300	0.2×1
備考 Notes	<p>※1 切込み量のapは軸方向の切込み深さ、aeはピックフィードを示します。 ※2 オイルミストクーラントをお奨めします。 ※3 回転数と送り速度は、同じ割合で調整してください。 ※4 切込み量、機械剛性により条件が異なることがあります。その都度調整してください。 ※5 工具突き出し量は、必要以上に出さないでください。 ※1 Depth of Cut: ap = Axial Depth of Cut / ae = Radial Depth of Cut. ※2 We recommend using oil mist coolant. ※3 Adjust milling conditions according to the volume of depth of cut and rigidity of machine. ※4 Adjust both spindle speed and feed at the same rate. ※5 Length of tool overhang must be as short as possible.</p>														

P プリハードン鋼
Prehardened Steel

M ステンレス鋼
Stainless Steel

S チタン合金
耐熱合金
Titanium Alloy
Heat Resistant Alloy

H 高硬度鋼
Hardened Steel
~55 HRC
~65 HRC



MRBTN230

規格追加
Lineup Expansion

サイズ R0.05 × 首角3° ~ R2 × 首角1°
Size R0.05 × neck taper angle 3° ~ R2 × neck taper angle 1°

∞ Premium
≤65 HRC

無限コーティングプレミアム ロングテーパネック2枚刃ボールエンドミル

MUGEN COATING PREMIUM 2-Flute Long Taper Neck Ball End Mill

テーパネックの採用で工具剛性が大幅アップ 加工面の傾斜角と同じ角度の首角が使えます

Taper neck to improve tool rigidity.
Option of same taper angle as inclined working angle

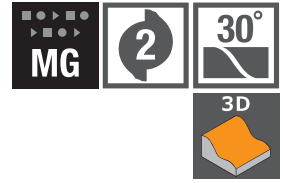

- 深部の加工で高精度化が図れるテーパネック形状のボールエンドミル。
- 最適化されたテーパネック形状と、無限コーティングプレミアムの採用で、高硬度鋼の加工時に真価を発揮します。
- 汎用性の高い2枚刃で、全209サイズをラインアップしました。
- Ⅱの規格・サイズは、特定商社在庫となります。詳しくはお問い合わせください。
- Taper neck type ball end mill improves accuracy for deep milling.
- Optimized taper neck design and MUGEN COATING PREMIUM realized to show its higher ability for hardened steels.
- Lineup of total 209 size with high versatility 2-flute end mills.
- Ⅱ : Semi-standard item, please inquire for price and delivery.

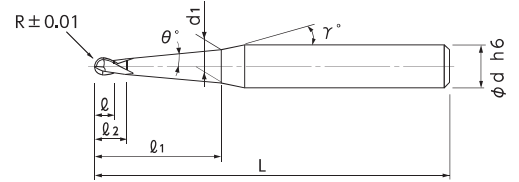

※首角(θ)は、加工面の傾斜角と同じ角度の工具が選べます。
※ Please select the tool with the same neck angle as the inclined angle of the milling surface.

【首部形状について】

表記の首角2(γ)は目安になります。被削材と首部の干渉が心配される時は、必ず実測での確認をお願いします。

【Neck Shape】

(γ) is reference value. Tool measurement required in order to avoid interference to the work material.

◆ Newサイズ

★ 再研磨可能 (シャンク長15mm以上のもの。詳細はお問い合わせください。)

単位 [寸法 : mm / 価格 : 円]

Unit [Size : mm / Retail Price : JPY]

コードNo. Code No.	(R)ボール半径 Radius	(θ)首角※ Neck Taper Angle	(l1)首下長 Under Neck Length	(d1)首元径 Neck Dia.	(l)刃長 Length of Cut	(l2)首下長2 Under Neck Length 2	(γ)首角2 Neck Taper Angle 2	(α)有効勾配角 Effective Inclined Angle	(d)シャンク径 Shank Dia.	(L)全長 Overall Length	標準価格 Retail Price	
◆ 08-00588-00571	R0.05	3°	0.5	0.14	0.07	0.2	12°	2°59'	4	50	11,500	
◆ 08-00588-00573			0.75	0.17	0.07	0.2	12°	2°59'	4	50	11,900	
◆ 08-00588-00771			R0.075	3°	1	0.24	0.1	0.3	12°	2°59'	4	50
◆ 08-00588-00773	1.5	0.29			0.1	0.3	12°	2°59'	4	50	13,500	
08-00588-01021	R0.1	30'	1.5	0.21	0.15	0.3	12°	0°29'	4	50	9,900	
08-00588-01023			2	0.22	0.15	0.3	12°	0°28'	4	50	10,400	
08-00588-01031		1°	30'	1.5	0.24	0.15	0.3	12°	0°58'	4	50	9,900
08-00588-01033				2	0.25	0.15	0.3	12°	0°58'	4	50	10,400
08-00588-01041		1°30'	30'	1.5	0.26	0.15	0.3	12°	1°29'	4	50	9,900
08-00588-01043				2	0.29	0.15	0.3	12°	1°28'	4	50	10,400
08-00588-01051		2°	30'	1.5	0.29	0.15	0.3	12°	1°59'	4	50	9,900
08-00588-01053				2	0.32	0.15	0.3	12°	1°59'	4	50	10,400
◆ 08-00588-01073		3°	30'	3	0.49	0.15	0.3	12°	2°59'	4	50	9,900
◆ 08-00588-01075				5	0.7	0.15	0.3	12°	2°59'	4	50	10,400
◆ 08-00588-01093		5°	30'	3	0.7	0.15	0.3	12°	4°59'	4	50	9,900
◆ 08-00588-01095				5	1.05	0.15	0.3	12°	4°59'	4	50	10,400
08-00588-01521	R0.15	30'	2	0.32	0.2	0.45	12°	0°28'	4	50	9,900	
08-00588-01523			3	0.34	0.2	0.45	12°	0°29'	4	50	10,400	
08-00588-01531		1°	30'	2	0.35	0.2	0.45	12°	0°59'	4	50	9,900
08-00588-01533				3	0.39	0.2	0.45	12°	0°59'	4	50	10,400
08-00588-01541		1°30'	30'	2	0.38	0.2	0.45	12°	1°29'	4	50	9,900
08-00588-01543				3	0.44	0.2	0.45	12°	1°29'	4	50	10,400
08-00588-01551		2°	30'	2	0.42	0.2	0.45	12°	1°58'	4	50	9,900
08-00588-01553				3	0.49	0.2	0.45	12°	1°59'	4	50	10,400
◆ 08-00588-01572		3°	30'	2	0.48	0.2	0.45	12°	2°59'	4	50	9,900
◆ 08-00588-01573				3	0.59	0.2	0.45	12°	2°59'	4	50	10,100
◆ 08-00588-01575		5°	30'	5	0.8	0.2	0.45	12°	2°59'	4	50	10,400
◆ 08-00588-01577				7	1.01	0.2	0.45	12°	2°59'	4	50	10,600
◆ 08-00588-01593	5°	30'	3	0.79	0.2	0.45	12°	4°59'	4	50	10,100	
◆ 08-00588-01595			5	1.14	0.2	0.45	12°	4°59'	4	50	10,400	
◆ 08-00588-01597	5°	30'	7	1.49	0.2	0.45	12°	4°59'	4	50	10,600	
08-00588-02021			R0.2	30'	3	0.43	0.3	0.6	12°	0°29'	4	50
08-00588-02023	4	0.45			0.3	0.6	12°	0°29'	4	50	7,700	
08-00588-02025	6	0.48			0.3	0.6	12°	0°29'	4	50	8,100	
08-00588-02031	1°	30'		3	0.48	0.3	0.6	12°	0°59'	4	50	7,700
08-00588-02033				4	0.51	0.3	0.6	12°	0°59'	4	50	7,700
08-00588-02035				6	0.58	0.3	0.6	12°	0°59'	4	50	8,100
08-00588-02041	1°30'	30'	3	0.53	0.3	0.6	12°	1°29'	4	50	7,700	
08-00588-02043			4	0.58	0.3	0.6	12°	1°29'	4	50	7,700	
08-00588-02045			6	0.68	0.3	0.6	12°	1°29'	4	50	8,100	

オーダー方法
How to Order

MRBTN230 ボール半径(R) × 首角(θ) × 首下長(l1) を指示してください。
When you order, indicate MRBTN230 (R) × (θ) × (l1).

加工事例
Machining case

W-014

無限コーティングプレミアム ロングテーパネック2枚刃ボールエンドミル

MUGEN COATING PREMIUM 2-Flute Long Taper Neck Ball End Mill

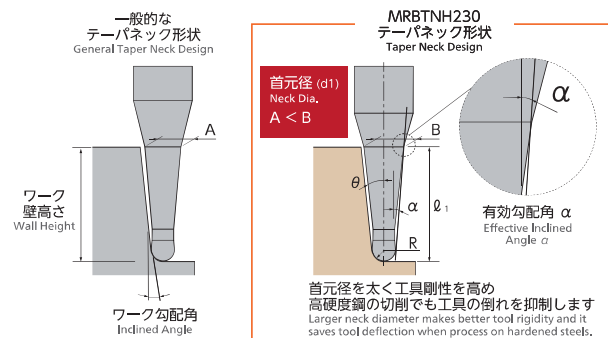

※首角(θ)は、加工面の傾斜角と同じ角度の工具が選べます。
※Please select the tool with the same neck angle as the inclined angle of the milling surface.

コードNo. Code No.	(R)ボール半径 Radius	(θ)首角※ Neck Taper Angle	(ℓ1)首下長 Under Neck Length	(d1)首元径 Neck Dia.	(ℓ)刃長 Length of Cut	(ℓ2)首下長2 Under Neck Length 2	(γ)首角2 Neck Taper Angle 2	(α)有効勾配角 Effective Inclined Angle	(d)シャンク径 Shank Dia.	(L)全長 Overall Length	標準価格 Retail Price		
08-00588-02051	R0.2	2°	3	0.58	0.3	0.6	12°	1°59'	4	50	7,700		
08-00588-02053			4	0.65	0.3	0.6	12°	1°59'	4	50	7,700		
08-00588-02055			6	0.79	0.3	0.6	12°	1°59'	4	50	8,100		
08-00588-02073		3°	5	0.88	0.3	0.6	12°	2°59'	4	50	7,700		
08-00588-02075			7	1.09	0.3	0.6	12°	2°59'	4	50	8,100		
08-00588-02093			5°	5	1.22	0.3	0.6	12°	4°59'	4	50	7,700	
08-00588-02095				7	1.57	0.3	0.6	12°	4°59'	4	50	8,100	
08-00588-02521	R0.25	30'	4	0.54	0.35	0.75	12°	0°29'	4	50	7,300		
08-00588-02523			5	0.56	0.35	0.75	12°	0°29'	4	50	7,500		
08-00588-02531		1°	4	0.61	0.35	0.75	12°	0°59'	4	50	7,300		
08-00588-02533			5	0.64	0.35	0.75	12°	0°59'	4	50	7,500		
08-00588-02541			4	0.67	0.35	0.75	12°	1°29'	4	50	7,300		
08-00588-02543		1°30'	5	0.73	0.35	0.75	12°	1°29'	4	50	7,500		
08-00588-02551			4	0.74	0.35	0.75	12°	1°59'	4	50	7,300		
08-00588-02553		2°	5	0.81	0.35	0.75	12°	1°59'	4	50	7,500		
08-00588-03021			4	0.64	0.45	0.9	12°	0°29'	4	50	6,800		
08-00588-03023		30'	5	0.66	0.45	0.9	12°	0°29'	4	50	7,100		
08-00588-03025	6		0.67	0.45	0.9	12°	0°29'	4	50	7,100			
08-00588-03027	8		0.71	0.45	0.9	12°	0°29'	4	50	7,300			
08-00588-03031	1°	4	0.7	0.45	0.9	12°	0°59'	4	50	6,800			
08-00588-03033		5	0.74	0.45	0.9	12°	0°59'	4	50	7,100			
08-00588-03035		6	0.77	0.45	0.9	12°	0°59'	4	50	7,100			
08-00588-03037		8	0.84	0.45	0.9	12°	0°59'	4	50	7,300			
08-00588-03041		1°30'	4	0.77	0.45	0.9	12°	1°29'	4	50	6,800		
08-00588-03043			5	0.82	0.45	0.9	12°	1°29'	4	50	7,100		
08-00588-03045			6	0.87	0.45	0.9	12°	1°29'	4	50	7,100		
08-00588-03047		8	0.98	0.45	0.9	12°	1°29'	4	50	7,300			
08-00588-03053	5		0.9	0.45	0.9	12°	1°59'	4	50	7,100			
08-00588-03055	2°	6	0.97	0.45	0.9	12°	1°59'	4	50	7,100			
08-00588-03057		8	1.11	0.45	0.9	12°	1°59'	4	50	7,300			
08-00588-03072	3°	4	0.96	0.45	0.9	12°	2°59'	4	50	7,100			
08-00588-03073		5	1.07	0.45	0.9	12°	2°59'	4	50	7,100			
08-00588-03075		7	1.28	0.45	0.9	12°	2°59'	4	50	7,300			
08-00588-03092		5°	5	1.4	0.45	0.9	12°	4°59'	4	50	7,100		
08-00588-03094			7	1.75	0.45	0.9	12°	4°59'	4	50	7,300		
08-00588-04021			R0.4	30'	8	0.89	0.6	1.2	12°	0°29'	4	60	7,600
08-00588-04023					12	0.96	0.6	1.2	12°	0°29'	4	60	8,000
08-00588-04031	8	1.03			0.6	1.2	12°	0°59'	4	60	7,600		
08-00588-04033	1°	12		1.17	0.6	1.2	12°	0°59'	4	60	8,000		
08-00588-04041		8		1.16	0.6	1.2	12°	1°29'	4	60	7,600		
08-00588-04043	1°30'	12		1.37	0.6	1.2	12°	1°29'	4	60	8,000		
08-00588-04051		8		1.29	0.6	1.2	12°	1°59'	4	60	7,600		
08-00588-04053	2°	12		1.57	0.6	1.2	12°	1°59'	4	60	8,000		
08-00588-04521		R0.45		30'	8	0.99	0.65	1.35	12°	0°29'	4	60	10,500
08-00588-04523	12				1.06	0.65	1.35	12°	0°29'	4	60	10,500	
08-00588-04525	16				1.13	0.65	1.35	12°	0°29'	4	60	10,500	
08-00588-04531	1°			8	1.12	0.65	1.35	12°	0°59'	4	60	10,500	
08-00588-04533			12	1.26	0.65	1.35	12°	0°59'	4	60	10,500		
08-00588-04535			16	1.4	0.65	1.35	12°	0°59'	4	60	10,500		
08-00588-04541	1°30'		8	1.25	0.65	1.35	12°	1°29'	4	60	10,500		
08-00588-04543			12	1.46	0.65	1.35	12°	1°29'	4	60	10,500		
08-00588-04545			16	1.67	0.65	1.35	12°	1°29'	4	60	10,500		
08-00588-05021			R0.5	30'	6	1.05	0.75	1.5	12°	0°29'	4	60	5,400
08-00588-05022	8	1.08			0.75	1.5	12°	0°29'	4	60	5,900		
08-00588-05023	10	1.12			0.75	1.5	12°	0°29'	4	60	6,500		
08-00588-05024	12	1.15			0.75	1.5	12°	0°29'	4	60	6,500		
08-00588-05025	16	1.22			0.75	1.5	12°	0°29'	4	60	6,800		
08-00588-05026	20	1.29			0.75	1.5	12°	0°29'	4	70	8,200		

P プリハードン鋼
Prehardened Steel

M ステンレス鋼
Stainless Steel

S チタン合金
耐熱合金
Titanium Alloy
Heat Resistant Alloy

H 高硬度鋼
Hardened Steel

~55 HRC

~65 HRC



MRBTNH230

無限コーティングプレミアム ロングテーパネック2枚刃ボールエンドミル

MUGEN COATING PREMIUM 2-Flute Long Taper Neck Ball End Mill

レギュラーライン
無限プレミアム
ロングネックタイプ

Regular Line
MUGEN PREMIUM
Long Neck Type

プリハードン鋼
Prehardened Steel

ステンレス鋼
Stainless Steel

【首部形状について】

表記の首角 (γ) は目安になります。被削材と首部の干渉が心配される時は、必ず実測での確認をお願いします。

(Neck Shape)

(γ) is reference value. Tool measurement required in order to avoid interference to the work material.

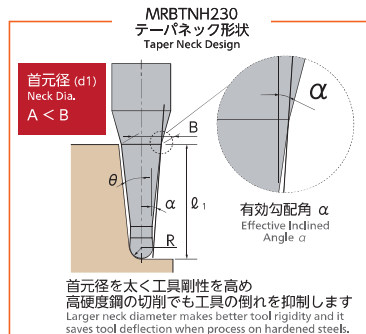
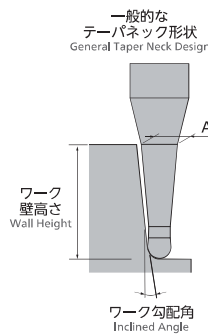

◆ Newサイズ

★再研磨可能 (シャンク長15mm以上のもの。詳細はお問い合わせください。)

単位 [寸法: mm / 価格: 円] Unit [Size: mm / Retail Price: JPY]

コードNo. Code No.	(R)ボール半径 Radius	(θ)首角※ Neck Taper Angle	(ℓ_1)首下長 Under Neck Length	(d1)首元径 Neck Dia.	(ℓ)刃長 Length of Cut	(ℓ_2)首下長2 Under Neck Length 2	(γ)首角2 Neck Taper Angle 2	(α)有効勾配角 Effective Inclined Angle	(d)シャンク径 Shank Dia.	(L)全長 Overall Length	標準価格 Retail Price	
★ 08-00588-05027	R0.5	30'	25	1.38	0.75	1.5	12°	0°29'	4	70	8,700	
★ 08-00588-05028			30	1.47	0.75	1.5	12°	0°29'	4	70	9,000	
★ 08-00588-05031			1°	6	1.15	0.75	1.5	12°	0°59'	4	60	5,400
★ 08-00588-05032				8	1.22	0.75	1.5	12°	0°59'	4	60	5,900
★ 08-00588-05033				10	1.29	0.75	1.5	12°	0°59'	4	60	6,500
★ 08-00588-05034				12	1.36	0.75	1.5	12°	0°59'	4	60	6,500
★ 08-00588-05035		16		1.5	0.75	1.5	12°	0°59'	4	60	6,800	
★ 08-00588-05036		20		1.63	0.75	1.5	12°	0°59'	4	70	8,200	
★ 08-00588-05037		25	1.81	0.75	1.5	12°	0°59'	4	70	8,700		
★ 08-00588-05038		30	1.98	0.75	1.5	12°	0°59'	4	70	9,000		
★ 08-00588-05041		1°30'	6	1.24	0.75	1.5	12°	1°29'	4	60	5,400	
★ 08-00588-05042			8	1.35	0.75	1.5	12°	1°29'	4	60	5,900	
★ 08-00588-05043			10	1.45	0.75	1.5	12°	1°29'	4	60	6,500	
★ 08-00588-05044			12	1.56	0.75	1.5	12°	1°29'	4	60	6,500	
★ 08-00588-05045			16	1.77	0.75	1.5	12°	1°29'	4	60	6,800	
★ 08-00588-05046			20	1.98	0.75	1.5	12°	1°29'	4	70	8,200	
★ 08-00588-05047		2°	25	2.24	0.75	1.5	12°	1°29'	4	70	8,700	
★ 08-00588-05048			30	2.5	0.75	1.5	12°	1°29'	4	70	9,000	
★ 08-00588-05052			3°	8	1.48	0.75	1.5	12°	1°59'	4	60	5,900
★ 08-00588-05053				10	1.62	0.75	1.5	12°	1°59'	4	60	6,500
★ 08-00588-05056				20	2.32	0.75	1.5	12°	1°59'	4	70	8,200
★ 08-00588-05058			30	3.01	0.75	1.5	12°	1°59'	4	70	9,000	
◆ 08-00588-05073		R0.6	1°	10	1.95	0.75	1.5	12°	2°59'	4	60	6,500
◆ 08-00588-05076				20	3	0.75	1.5	12°	2°59'	4	70	8,200
◆ 08-00588-05078	30			4.05	0.75	1.5	12°	2°59'	6	70	9,000	
◆ 08-00588-06031	1°30'		6	1.34	0.9	1.8	12°	0°59'	4	60	9,600	
◆ 08-00588-06032			8	1.41	1	1.8	12°	0°59'	4	60	9,700	
◆ 08-00588-06033			10	1.48	1	1.8	12°	0°59'	4	60	9,900	
◆ 08-00588-06036			20	1.83	1	1.8	12°	0°59'	4	70	14,000	
◆ 08-00588-06038			30	2.18	1	1.8	12°	0°59'	4	70	15,000	
◆ 08-00588-06041			3°	6	1.43	1	1.8	12°	1°29'	4	60	9,600
◆ 08-00588-06042	8			1.54	1	1.8	12°	1°29'	4	60	9,700	
◆ 08-00588-06043	1°30'			10	1.64	1	1.8	12°	1°29'	4	60	9,900
◆ 08-00588-06046				20	2.17	1	1.8	12°	1°29'	4	70	14,000
◆ 08-00588-06048		30		2.69	1	1.8	12°	1°29'	4	70	15,000	
◆ 08-00588-06073	3°	10		2.14	1	1.8	12°	2°59'	4	60	11,000	
◆ 08-00588-06076		20	3.19	0.9	1.8	12°	2°59'	4	70	14,000		
◆ 08-00588-06078		35	4.76	0.9	1.8	12°	2°59'	6	80	15,000		
★ 08-00588-07521	R0.75	30'	10	1.61	1.1	2.25	12°	0°29'	4	60	6,800	
★ 08-00588-07523			15	1.69	1.1	2.25	12°	0°29'	4	60	7,400	
★ 08-00588-07525			20	1.78	1.1	2.25	12°	0°29'	4	70	8,200	
★ 08-00588-07527			25	1.87	1.1	2.25	12°	0°29'	4	70	9,000	
★ 08-00588-07529			30	1.96	1.1	2.25	12°	0°29'	4	70	10,300	
★ 08-00588-07531		1°	10	1.77	1.1	2.25	12°	0°59'	4	60	6,800	
★ 08-00588-07533			15	1.94	1.1	2.25	12°	0°59'	4	60	7,400	
★ 08-00588-07535			20	2.12	1.1	2.25	12°	0°59'	4	70	8,200	
★ 08-00588-07537			25	2.29	1.1	2.25	12°	0°59'	4	70	9,000	
★ 08-00588-07539			30	2.47	1.1	2.25	12°	0°59'	4	70	10,300	
★ 08-00588-07541			1°30'	10	1.93	1.1	2.25	12°	1°29'	4	60	6,800
★ 08-00588-07543		15		2.19	1.1	2.25	12°	1°29'	4	60	7,400	
★ 08-00588-07545		20		2.45	1.1	2.25	12°	1°29'	4	70	8,200	
★ 08-00588-07551		10		2.09	1.1	2.25	12°	1°59'	4	60	6,800	
★ 08-00588-07553		2°		15	2.44	1.1	2.25	12°	1°59'	4	60	7,400
★ 08-00588-07555				20	2.79	1.1	2.25	12°	1°59'	4	70	9,000
★ 08-00588-10021				30'	12	2.14	1.5	3	12°	0°29'	4	60
★ 08-00588-10022		16	2.21		1.5	3	12°	0°29'	4	60	6,200	

チタン合金
耐熱合金
Titanium Alloy
Heat Resistant Alloy

~55 HRC
~65 HRC
高硬度鋼
Hardened Steel

コーティング
Coating
ロングネック
Long Neck
テーパネック
Taper Neck

オーダー方法
How to Order

MRBTNH230 ボール半径 (R) × 首角 (θ) × 首下長 (ℓ_1) を指示してください。
When you order, indicate MRBTNH230 (R) × (θ) × (ℓ_1).

無限コーティングプレミアム ロングテーパネック2枚刃ボールエンドミル

MUGEN COATING PREMIUM 2-Flute Long Taper Neck Ball End Mill

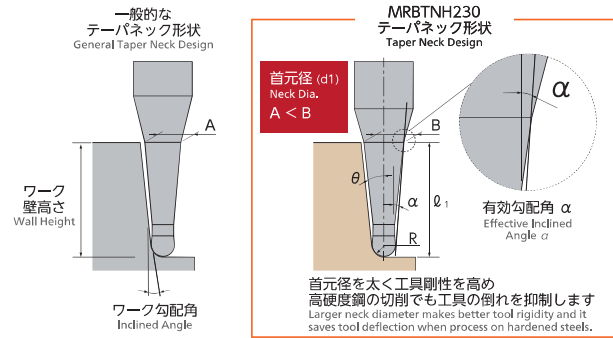

※首角(θ)は、加工面の傾斜角と同じ角度の工具が選べます。

※Please select the tool with the same neck angle as the inclined angle of the milling surface.

コードNo. Code No.	(R)ボール半径 Radius	(θ)首角※ Neck Taper Angle	(ℓ1)首下長 Under Neck Length	(d1)首元径 Neck Dia.	(ℓ)刃長 Length of Cut	(ℓ2)首下長2 Under Neck Length 2	(γ)首角2 Neck Taper Angle 2	(α)有効勾配角 Effective Inclined Angle	(d)シャンク径 Shank Dia.	(L)全長 Overall Length	標準価格 Retail Price
★ 08-00588-10023	R1	30°	20	2.28	1.5	3	12°	0°29′	4	70	7,400
★ 08-00588-10024			25	2.37	1.5	3	12°	0°29′	4	70	8,200
★ 08-00588-10025			30	2.46	1.5	3	12°	0°29′	4	70	9,000
★ 08-00588-10026			35	2.54	1.5	3	12°	0°29′	4	80	9,800
★ 08-00588-10027			40	2.63	1.5	3	12°	0°29′	4	80	10,600
★ 08-00588-10028			50	2.81	1.5	3	12°	0°30′	4	90	12,000
★ 08-00588-10031		1°	12	2.33	1.5	3	12°	0°59′	4	60	6,000
★ 08-00588-10032			16	2.47	1.5	3	12°	0°59′	4	60	6,200
★ 08-00588-10033			20	2.61	1.5	3	12°	0°59′	4	70	7,400
★ 08-00588-10034			25	2.79	1.5	3	12°	0°59′	4	70	8,200
★ 08-00588-10035			30	2.96	1.5	3	12°	0°59′	4	70	9,000
★ 08-00588-10036			35	3.14	1.5	3	12°	0°59′	6	80	11,600
★ 08-00588-10037		1°30′	40	3.31	1.5	3	12°	0°59′	6	80	12,200
★ 08-00588-10038			50	3.66	1.5	3	12°	0°59′	6	90	13,500
★ 08-00588-10041			12	2.53	1.5	3	12°	1°29′	4	60	6,000
★ 08-00588-10042			16	2.74	1.5	3	12°	1°29′	4	60	6,200
★ 08-00588-10043			20	2.95	1.5	3	12°	1°29′	4	70	7,400
★ 08-00588-10044			25	3.21	1.5	3	12°	1°29′	4	70	8,200
★ 08-00588-10045		2°	30	3.47	1.5	3	12°	1°29′	6	70	10,600
★ 08-00588-10046			35	3.73	1.5	3	12°	1°29′	6	80	11,600
★ 08-00588-10047			40	3.99	1.5	3	12°	1°29′	6	80	12,200
★ 08-00588-10048			50	4.52	1.5	3	12°	1°30′	6	90	13,500
★ 08-00588-10051			12	2.72	1.5	3	12°	1°59′	4	60	6,000
★ 08-00588-10052			16	3	1.5	3	12°	1°59′	4	60	6,200
★ 08-00588-10053		R1.5	20	3.28	1.5	3	12°	1°59′	4	70	7,800
★ 08-00588-10054			25	3.63	1.5	3	12°	1°59′	6	70	8,600
★ 08-00588-10055			30	3.98	1.5	3	12°	1°59′	6	70	10,600
★ 08-00588-10057			40	4.67	1.5	3	12°	1°59′	6	80	12,200
★ 08-00588-10058			50	5.37	1.5	3	12°	2°00′	6	90	13,500
★ 08-00588-15021			30°	15	3.13	2.5	4.5	12°	0°29′	6	70
★ 08-00588-15022		20		3.22	2.5	4.5	12°	0°29′	6	70	8,700
★ 08-00588-15023		25		3.31	2.5	4.5	12°	0°29′	6	70	9,400
★ 08-00588-15024		30		3.4	2.5	4.5	12°	0°29′	6	70	10,100
★ 08-00588-15025		40		3.57	2.5	4.5	12°	0°29′	6	80	11,200
★ 08-00588-15026		50		3.74	2.5	4.5	12°	0°29′	6	90	13,000
★ 08-00588-15031		1°	15	3.37	2.5	4.5	12°	0°59′	6	70	8,200
★ 08-00588-15032	20		3.54	2.5	4.5	12°	0°59′	6	70	8,700	
★ 08-00588-15033	25		3.72	2.5	4.5	12°	0°59′	6	70	9,400	
★ 08-00588-15034	30		3.89	2.5	4.5	12°	0°59′	6	70	10,100	
★ 08-00588-15035	40		4.24	2.5	4.5	12°	0°59′	6	80	11,200	
★ 08-00588-15036	50		4.59	2.5	4.5	12°	0°59′	6	90	13,000	
★ 08-00588-15041	1°30′	15	3.61	2.5	4.5	12°	1°29′	6	70	8,200	
★ 08-00588-15042		20	3.87	2.5	4.5	12°	1°29′	6	70	8,700	
★ 08-00588-15043		25	4.13	2.5	4.5	12°	1°29′	6	70	9,400	
★ 08-00588-15044		30	4.39	2.5	4.5	12°	1°29′	6	70	10,100	
★ 08-00588-15045		40	4.91	2.5	4.5	12°	1°29′	6	80	11,200	
★ 08-00588-15046		50	5.44	2.5	4.5	12°	1°29′	6	90	13,000	
★ 08-00588-15051	2°	15	3.84	2.5	4.5	12°	1°59′	6	70	8,200	
★ 08-00588-15052		20	4.19	2.5	4.5	12°	1°59′	6	70	8,700	
★ 08-00588-15054		30	4.89	2.5	4.5	12°	1°59′	6	70	11,700	
★ 08-00588-20031	R2	1°	20	4.57	3	6	12°	0°59′	6	80	10,800
★ 08-00588-20033			30	4.92	3	6	12°	0°59′	6	80	10,800
★ 08-00588-20035			40	5.26	3	6	12°	0°59′	6	80	14,200
★ 08-00588-20036			50	5.62	3	6	12°	0°59′	6	90	15,000
★ 08-00588-20037			61.1	6	3	6	-	0°59′	6	110	16,200

P プリハードン鋼
Prehardened Steel

M ステンレス鋼
Stainless Steel

S チタン合金
耐熱合金
Titanium Alloy
Heat Resistant Alloy

H 高硬度鋼
Hardened Steel
~55 HRC
~65 HRC

コーティング
Coating
テーパネック
Taper Neck
ボールエンドミル
Ball End Mill

MRBTN230

切削条件参考表

Recommended Milling Conditions

被削材 Work Material			調質鋼 Prehardened Steels HPM・NAK (~41HRC)				高硬度鋼 Hardened Steels STAVAX・SKD61 (~52HRC)				高硬度鋼 Hardened Steels SKD11・PD613 (~62HRC)				ハイス High Speed Steels SKH・HAP (~65HRC)				
Rサイズ Radius	首角 Neck Taper Angle	首下長 Under Neck Length	切込み量 Depth of Cut		送り速度 Feed	回転数 Spindle Speed	切込み量 Depth of Cut		送り速度 Feed	回転数 Spindle Speed	切込み量 Depth of Cut		送り速度 Feed	回転数 Spindle Speed	切込み量 Depth of Cut		送り速度 Feed	回転数 Spindle Speed	
			a _p mm	a _e mm	mm/min	min ⁻¹	a _p mm	a _e mm	mm/min	min ⁻¹	a _p mm	a _e mm	mm/min	min ⁻¹	a _p mm	a _e mm	mm/min	min ⁻¹	
0.05	3°	0.5	0.005	0.005	120	40,000	0.003	0.005	100	40,000	0.002	0.005	70	40,000	0.002	0.003	50	40,000	
		0.75	0.003	0.005	100	40,000	0.002	0.003	70	40,000	0.001	0.003	50	40,000	0.001	0.002	30	40,000	
0.075	3°	1	0.005	0.005	180	40,000	0.003	0.005	150	40,000	0.002	0.005	120	40,000	0.002	0.003	70	40,000	
		1.5	0.003	0.005	100	40,000	0.002	0.003	70	40,000	0.001	0.003	50	40,000	0.001	0.002	30	40,000	
0.1	30°	1.5	0.003	0.01	200	40,000	0.003	0.005	180	40,000	0.002	0.003	140	40,000	0.001	0.002	100	40,000	
		2	0.003	0.005	150	40,000	0.002	0.003	120	40,000	0.001	0.002	100	40,000	0.001	0.002	60	40,000	
	1°	1.5	0.003	0.007	200	40,000	0.003	0.005	180	40,000	0.002	0.003	140	40,000	0.001	0.002	100	40,000	
		2	0.003	0.007	160	40,000	0.003	0.005	140	40,000	0.002	0.003	120	40,000	0.001	0.002	80	40,000	
	1°30'	1.5	0.005	0.01	230	40,000	0.003	0.005	200	40,000	0.002	0.003	160	40,000	0.001	0.002	120	40,000	
		2	0.003	0.01	200	40,000	0.003	0.005	160	40,000	0.002	0.003	140	40,000	0.001	0.002	100	40,000	
	2°	1.5	0.007	0.01	250	40,000	0.005	0.01	230	40,000	0.003	0.003	180	40,000	0.002	0.003	140	40,000	
		2	0.003	0.01	230	40,000	0.003	0.005	180	40,000	0.002	0.003	140	40,000	0.001	0.002	100	40,000	
	3°	3	0.005	0.01	230	40,000	0.003	0.005	180	40,000	0.002	0.003	140	40,000	0.001	0.002	100	40,000	
		5	0.003	0.005	200	40,000	0.002	0.003	160	40,000	0.001	0.002	120	40,000	0.001	0.002	80	40,000	
	5°	3	0.007	0.01	250	40,000	0.005	0.01	200	40,000	0.003	0.005	160	40,000	0.002	0.003	120	40,000	
		5	0.005	0.01	230	40,000	0.003	0.005	180	40,000	0.002	0.003	140	40,000	0.001	0.002	100	40,000	
0.15	30°	2	0.003	0.007	230	40,000	0.003	0.005	200	40,000	0.002	0.003	160	40,000	0.002	0.002	120	40,000	
		3	0.003	0.005	180	40,000	0.002	0.003	140	40,000	0.001	0.002	120	40,000	0.001	0.002	70	40,000	
	1°	2	0.003	0.01	230	40,000	0.003	0.005	200	40,000	0.002	0.003	160	40,000	0.002	0.002	120	40,000	
		3	0.003	0.007	200	40,000	0.003	0.005	160	40,000	0.002	0.003	140	40,000	0.001	0.002	90	40,000	
	1°30'	2	0.005	0.01	250	40,000	0.003	0.005	230	40,000	0.002	0.003	180	40,000	0.002	0.002	140	40,000	
		3	0.003	0.01	220	40,000	0.003	0.005	180	40,000	0.002	0.003	150	40,000	0.001	0.002	110	40,000	
	2°	2	0.007	0.01	280	40,000	0.005	0.01	250	40,000	0.003	0.003	200	40,000	0.002	0.003	160	40,000	
		3	0.003	0.01	250	40,000	0.003	0.005	200	40,000	0.002	0.003	160	40,000	0.002	0.002	120	40,000	
	3°	2	0.01	0.015	300	40,000	0.007	0.01	280	40,000	0.005	0.007	230	40,000	0.003	0.005	200	40,000	
		3	0.007	0.015	280	40,000	0.005	0.01	250	40,000	0.003	0.007	200	40,000	0.002	0.005	180	40,000	
	5°	5	0.007	0.01	250	40,000	0.005	0.007	230	40,000	0.003	0.005	180	40,000	0.002	0.003	160	40,000	
		7	0.005	0.007	230	40,000	0.003	0.005	200	40,000	0.002	0.003	160	40,000	0.001	0.002	140	40,000	
0.2	30°	3	0.01	0.015	300	40,000	0.007	0.01	280	40,000	0.005	0.007	230	40,000	0.003	0.005	200	40,000	
		5	0.007	0.015	280	40,000	0.005	0.01	250	40,000	0.003	0.007	200	40,000	0.002	0.005	180	40,000	
	1°	3	0.01	0.02	360	40,000	0.007	0.01	300	40,000	0.005	0.007	240	40,000	0.003	0.005	160	40,000	
		4	0.007	0.01	240	40,000	0.005	0.005	160	40,000	0.003	0.003	120	40,000	0.002	0.003	100	40,000	
	1°30'	3	0.015	0.02	450	40,000	0.007	0.01	360	40,000	0.005	0.007	280	40,000	0.003	0.005	240	40,000	
		4	0.01	0.02	400	40,000	0.007	0.01	300	40,000	0.005	0.007	240	40,000	0.003	0.005	160	40,000	
	2°	3	0.015	0.02	480	40,000	0.007	0.01	400	40,000	0.005	0.007	320	40,000	0.003	0.005	280	40,000	
		4	0.01	0.02	400	40,000	0.007	0.01	320	40,000	0.005	0.007	260	40,000	0.003	0.005	220	40,000	
	3°	5	0.01	0.02	400	40,000	0.007	0.01	320	40,000	0.005	0.007	240	40,000	0.003	0.005	220	40,000	
		7	0.01	0.015	320	40,000	0.005	0.007	240	40,000	0.003	0.005	180	40,000	0.002	0.003	140	40,000	
	5°	5	0.015	0.02	420	40,000	0.007	0.01	320	40,000	0.005	0.007	240	40,000	0.003	0.005	220	40,000	
		7	0.015	0.015	400	40,000	0.007	0.01	320	40,000	0.005	0.007	240	40,000	0.003	0.005	220	40,000	
0.25	30°	4	0.012	0.02	500	40,000	0.007	0.01	450	40,000	0.005	0.007	360	40,000	0.003	0.005	280	40,000	
		5	0.008	0.01	460	40,000	0.005	0.005	400	40,000	0.003	0.003	300	40,000	0.002	0.003	240	40,000	
	1°	4	0.015	0.03	580	40,000	0.007	0.01	520	40,000	0.005	0.007	400	40,000	0.003	0.005	320	40,000	
		5	0.012	0.02	500	40,000	0.007	0.01	440	40,000	0.005	0.007	360	40,000	0.003	0.005	260	40,000	
	1°30'	4	0.015	0.035	640	40,000	0.01	0.02	560	40,000	0.007	0.01	480	40,000	0.005	0.007	360	40,000	
		5	0.012	0.02	500	40,000	0.007	0.01	460	40,000	0.005	0.007	380	40,000	0.003	0.005	280	40,000	
	2°	4	0.015	0.035	700	40,000	0.01	0.02	640	40,000	0.007	0.01	540	40,000	0.005	0.007	400	40,000	
		5	0.015	0.03	600	40,000	0.007	0.015	520	40,000	0.005	0.01	420	40,000	0.003	0.007	300	40,000	
	0.3	30°	4	0.025	0.07	900	40,000	0.02	0.03	800	40,000	0.01	0.03	580	40,000	0.01	0.02	450	30,000
			5	0.025	0.05	750	40,000	0.02	0.03	700	35,000	0.01	0.02	500	35,000	0.008	0.015	420	30,000
			6	0.015	0.02	500	35,000	0.01	0.015	460	30,000	0.007	0.01	400	30,000	0.005	0.008	360	30,000

プリハードン鋼 P
 Prehardened Steel

ステンレス鋼 M
 Stainless Steel

チタン合金 耐熱合金 S
 Titanium Alloy Heat Resistant Alloy

高硬度鋼 H
 Hardened Steel

コーティング
 Coating

ロングネック
 Long Neck

ボールノーズミリング
 Ball Nose Milling

MRBTN230

レギュラーライン
無限プレミアム
ロングネックタイプ

Regular Line
MUGEN PREMIUM
Long Neck Type

切削条件参考表 Recommended Milling Conditions

被削材 Work Material			調質鋼 Prehardened Steels HPM・NAK (~41HRC)				高硬度鋼 Hardened Steels STAVAX・SKD61 (~52HRC)				高硬度鋼 Hardened Steels SKD11・PD613 (~62HRC)				ハイス High Speed Steels SKH・HAP (~65HRC)				
Rサイズ Radius	首角 Neck Taper Angle	首下長 Under Neck Length	切込み量 Depth of Cut		送り速度 Feed	回転数 Spindle Speed	切込み量 Depth of Cut		送り速度 Feed	回転数 Spindle Speed	切込み量 Depth of Cut		送り速度 Feed	回転数 Spindle Speed	切込み量 Depth of Cut		送り速度 Feed	回転数 Spindle Speed	
			a _p mm	a _e mm	mm/min	min ⁻¹	a _p mm	a _e mm	mm/min	min ⁻¹	a _p mm	a _e mm	mm/min	min ⁻¹	a _p mm	a _e mm	mm/min	min ⁻¹	
0.3	30°	8	0.008	0.015	400	30,000	0.005	0.007	360	25,000	0.003	0.005	300	25,000	0.003	0.003	260	20,000	
			0.025	0.07	900	40,000	0.02	0.03	800	40,000	0.01	0.03	580	40,000	0.01	0.02	450	30,000	
			0.025	0.05	750	40,000	0.02	0.03	700	35,000	0.01	0.02	500	35,000	0.008	0.015	420	30,000	
	1°	8	0.02	0.04	540	35,000	0.01	0.02	500	30,000	0.007	0.015	460	30,000	0.007	0.01	400	30,000	
			0.01	0.02	460	35,000	0.007	0.01	400	30,000	0.005	0.007	360	30,000	0.003	0.005	320	30,000	
			0.025	0.07	1,000	40,000	0.02	0.03	900	40,000	0.01	0.03	620	40,000	0.01	0.02	480	30,000	
	1°30'	8	0.025	0.05	800	40,000	0.02	0.03	750	40,000	0.01	0.03	560	40,000	0.01	0.02	440	30,000	
			0.025	0.04	750	40,000	0.02	0.025	700	35,000	0.01	0.02	500	35,000	0.008	0.015	420	30,000	
			0.013	0.02	500	35,000	0.01	0.015	460	30,000	0.007	0.01	400	30,000	0.005	0.008	360	30,000	
	2°	8	0.025	0.07	1,000	40,000	0.02	0.03	900	40,000	0.01	0.03	620	40,000	0.01	0.02	480	30,000	
			0.025	0.05	800	40,000	0.02	0.03	750	35,000	0.01	0.02	560	35,000	0.008	0.015	440	30,000	
			0.02	0.03	540	35,000	0.01	0.02	500	30,000	0.007	0.015	460	30,000	0.007	0.01	400	30,000	
	3°	8	0.03	0.1	1,200	40,000	0.03	0.05	1,200	40,000	0.025	0.03	800	40,000	0.02	0.025	600	30,000	
			0.03	0.07	1,000	40,000	0.03	0.05	1,000	40,000	0.025	0.03	600	40,000	0.02	0.025	500	30,000	
			0.025	0.05	800	40,000	0.02	0.03	900	35,000	0.015	0.025	500	35,000	0.01	0.02	400	30,000	
	5°	8	0.03	0.1	1,200	40,000	0.03	0.05	1,200	40,000	0.025	0.03	800	40,000	0.02	0.025	600	30,000	
			0.03	0.07	1,000	40,000	0.03	0.05	1,000	35,000	0.025	0.03	600	35,000	0.02	0.025	500	30,000	
			0.02	0.03	540	35,000	0.01	0.02	500	30,000	0.007	0.015	460	30,000	0.007	0.01	400	30,000	
0.4	30°	8	0.015	0.03	720	35,000	0.012	0.02	600	30,000	0.007	0.015	540	30,000	0.005	0.01	480	25,000	
			0.005	0.01	460	30,000	0.005	0.005	400	25,000	0.003	0.003	360	25,000	0.002	0.003	320	25,000	
			0.03	0.05	800	35,000	0.02	0.03	700	30,000	0.01	0.02	680	30,000	0.007	0.01	520	25,000	
	1°	8	0.005	0.01	480	30,000	0.005	0.005	420	25,000	0.003	0.003	380	25,000	0.002	0.003	340	25,000	
			0.05	0.07	900	35,000	0.03	0.05	800	30,000	0.02	0.03	760	30,000	0.01	0.02	560	25,000	
			0.015	0.03	640	35,000	0.01	0.02	500	30,000	0.007	0.01	500	30,000	0.005	0.01	480	25,000	
	2°	8	0.05	0.08	1,000	35,000	0.03	0.05	900	30,000	0.02	0.03	760	30,000	0.01	0.02	560	25,000	
			0.03	0.05	800	35,000	0.02	0.03	700	30,000	0.01	0.02	600	30,000	0.007	0.01	520	25,000	
			0.05	0.07	1,400	35,000	0.03	0.05	1,100	30,000	0.02	0.03	1,000	30,000	0.015	0.025	800	25,000	
	0.45	30°	8	0.03	0.05	1,000	30,000	0.02	0.03	800	25,000	0.015	0.025	600	25,000	0.01	0.015	400	25,000
				0.01	0.02	500	25,000	0.007	0.015	400	20,000	0.005	0.01	300	20,000	0.003	0.005	250	20,000
				0.05	0.07	1,500	35,000	0.03	0.05	1,200	30,000	0.02	0.03	1,000	30,000	0.015	0.025	800	25,000
1°		8	0.03	0.05	1,200	30,000	0.02	0.03	1,000	25,000	0.015	0.025	700	25,000	0.01	0.015	500	25,000	
			0.012	0.025	600	25,000	0.01	0.02	500	20,000	0.007	0.015	400	20,000	0.005	0.01	350	20,000	
			0.07	0.1	1,600	35,000	0.05	0.05	1,200	30,000	0.03	0.03	1,000	30,000	0.02	0.025	800	25,000	
1°30'		8	0.03	0.05	1,400	35,000	0.03	0.05	1,000	30,000	0.025	0.03	700	25,000	0.01	0.02	550	25,000	
			0.015	0.025	800	30,000	0.012	0.025	600	25,000	0.01	0.02	500	20,000	0.007	0.015	400	20,000	
			0.1	0.2	1,600	35,000	0.05	0.1	1,400	30,000	0.04	0.05	1,200	25,000	0.02	0.05	740	20,000	
0.5		30°	8	0.08	0.2	1,300	35,000	0.04	0.06	1,200	30,000	0.03	0.04	950	25,000	0.02	0.03	680	20,000
				0.03	0.06	1,000	30,000	0.03	0.05	820	25,000	0.015	0.03	750	20,000	0.01	0.02	500	18,000
				0.03	0.06	1,000	30,000	0.03	0.05	820	25,000	0.015	0.03	750	20,000	0.01	0.02	500	18,000
	0.03			0.06	820	30,000	0.03	0.05	720	25,000	0.015	0.03	620	20,000	0.01	0.02	450	18,000	
	0.012			0.025	540	25,000	0.008	0.02	500	20,000	0.005	0.01	420	18,000	0.003	0.006	350	16,000	
	0.005			0.01	300	20,000	0.005	0.005	250	18,000	0.003	0.005	200	16,000	0.002	0.003	150	14,000	
	0.005			0.005	180	20,000	0.003	0.005	150	18,000	0.002	0.005	120	16,000	0.002	0.002	85	14,000	
	0.003			0.005	120	16,000	0.003	0.003	100	16,000	0.002	0.003	75	14,000	0.001	0.002	60	12,000	
	0.1			0.25	2,000	35,000	0.05	0.15	1,800	30,000	0.04	0.1	1,600	25,000	0.03	0.05	920	20,000	
	1°	8	0.1	0.2	1,600	35,000	0.05	0.1	1,400	30,000	0.04	0.05	1,200	25,000	0.02	0.05	740	20,000	
			0.05	0.1	1,200	35,000	0.04	0.06	1,000	30,000	0.03	0.04	800	25,000	0.02	0.03	560	20,000	
			0.04	0.06	1,000	30,000	0.03	0.05	820	25,000	0.02	0.03	700	20,000	0.01	0.02	500	18,000	
			0.015	0.025	600	25,000	0.01	0.025	500	20,000	0.007	0.02	450	18,000	0.005	0.01	400	16,000	
			0.012	0.025	500	25,000	0.008	0.02	400	20,000	0.005	0.01	360	18,000	0.003	0.006	320	16,000	
			0.005	0.01	300	20,000	0.005	0.005	250	18,000	0.003	0.005	200	16,000	0.002	0.003	150	14,000	
			0.005	0.005	200	20,000	0.003	0.005	150	18,000	0.002	0.005	120	16,000	0.002	0.002	85	14,000	
			0.15	0.25	2,000	40,000	0.1	0.2	2,000	40,000	0.05	0.15	1,600	30,000	0.05	0.1	1,200	25,000	
			0.1	0.2	1,800	35,000	0.05	0.1	1,600	30,000	0.04	0.05	1,200	25,000	0.02	0.05	800	20,000	
1°30'	8	0.08	0.2	1,400	35,000	0.04	0.06	1,200	30,000	0.03	0.04	900	25,000	0.02	0.03	700	20,000		
		0.05	0.1	1,200	35,000	0.04	0.06	1,000	30,000	0.03	0.04	800	25,000	0.02	0.03	550	20,000		
		0.03	0.05	800	30,000	0.02	0.05	700	25,000	0.02	0.03	600	20,000	0.01	0.02	500	18,000		
		0.015	0.025	600	25,000	0.01	0.025	500	20,000	0.007	0.02	450	18,000	0.005	0.01	400	16,000		
		0.012	0.025	500	25,000	0.008	0.02	400	20,000	0.005	0.01	350	18,000	0.003	0.006	300	16,000		
		0.01	0.02	400	20,000	0.005	0.01	300	20,000	0.003	0.007	250	18,000	0.002	0.005	200	16,000		

P プリハードン鋼
Prehardened Steel

M ステンレス鋼
Stainless Steel

S チタン合金
耐熱合金
Titanium Alloy
Heat Resistant Alloy

H 高硬度鋼
Hardened Steel
~55 HRC
~65 HRC

コーティング
Coating
コーティングボール
Coated ball
コーティング
Coating
コーティングボール
Coated ball

MRBTN230

切削条件参考表

Recommended Milling Conditions

被削材 Work Material			調質鋼 Prehardened Steels HPM・NAK (~41HRC)				高硬度鋼 Hardened Steels STAVAX・SKD61 (~52HRC)				高硬度鋼 Hardened Steels SKD11・PD613 (~62HRC)				ハイス High Speed Steels SKH・HAP (~65HRC)			
Rサイズ Radius	首角 Neck Taper Angle	首下長 Under Neck Length	切込み量 Depth of Cut		送り速度 Feed	回転数 Spindle Speed	切込み量 Depth of Cut		送り速度 Feed	回転数 Spindle Speed	切込み量 Depth of Cut		送り速度 Feed	回転数 Spindle Speed	切込み量 Depth of Cut		送り速度 Feed	回転数 Spindle Speed
			a _p mm	a _e mm	mm/min	min ⁻¹	a _p mm	a _e mm	mm/min	min ⁻¹	a _p mm	a _e mm	mm/min	min ⁻¹	a _p mm	a _e mm	mm/min	min ⁻¹
0.5	2°	8	0.1	0.2	2,000	35,000	0.05	0.1	1,600	30,000	0.04	0.05	1,200	25,000	0.02	0.05	900	20,000
		10	0.05	0.2	1,600	35,000	0.04	0.1	1,200	30,000	0.03	0.05	1,000	25,000	0.02	0.05	700	20,000
		20	0.03	0.05	800	30,000	0.02	0.05	700	25,000	0.02	0.03	600	20,000	0.01	0.02	450	18,000
		30	0.015	0.03	600	20,000	0.01	0.03	500	20,000	0.007	0.02	400	18,000	0.005	0.01	350	16,000
	3°	10	0.1	0.2	2,000	35,000	0.05	0.1	1,600	30,000	0.03	0.07	1,200	25,000	0.025	0.05	800	20,000
		20	0.04	0.1	1,200	30,000	0.03	0.05	1,000	25,000	0.02	0.03	800	20,000	0.015	0.025	500	18,000
0.6	1°	6	0.15	0.3	2,500	35,000	0.07	0.15	2,000	30,000	0.05	0.1	1,500	25,000	0.03	0.07	1,000	20,000
		8	0.1	0.25	2,000	35,000	0.07	0.1	1,600	30,000	0.05	0.07	1,200	25,000	0.03	0.05	800	20,000
		10	0.1	0.2	1,200	35,000	0.05	0.1	1,000	30,000	0.03	0.07	800	25,000	0.025	0.05	600	20,000
		20	0.02	0.03	600	25,000	0.015	0.03	500	20,000	0.01	0.025	450	18,000	0.007	0.02	400	16,000
	1°30'	6	0.2	0.3	3,000	40,000	0.1	0.2	2,400	35,000	0.07	0.15	2,000	30,000	0.05	0.1	1,600	25,000
		8	0.15	0.25	2,400	35,000	0.07	0.15	1,600	30,000	0.05	0.1	1,400	25,000	0.03	0.07	1,000	20,000
		10	0.15	0.2	2,000	35,000	0.07	0.1	1,200	30,000	0.05	0.07	1,000	25,000	0.03	0.05	800	20,000
		20	0.05	0.1	1,200	25,000	0.03	0.05	600	20,000	0.025	0.03	500	18,000	0.02	0.025	450	16,000
	3°	6	0.2	0.3	3,000	40,000	0.1	0.2	2,400	35,000	0.07	0.15	2,000	30,000	0.05	0.1	1,600	25,000
		8	0.15	0.25	2,400	35,000	0.07	0.15	1,600	30,000	0.05	0.1	1,400	25,000	0.03	0.07	1,000	20,000
		10	0.15	0.25	3,000	35,000	0.1	0.2	2,000	30,000	0.07	0.15	1,600	25,000	0.05	0.1	1,200	20,000
		20	0.1	0.15	2,000	30,000	0.07	0.1	1,400	25,000	0.05	0.07	1,000	20,000	0.03	0.05	800	18,000
0.75	30'	6	0.2	0.3	3,000	40,000	0.1	0.2	2,400	35,000	0.07	0.15	2,000	30,000	0.05	0.1	1,600	25,000
		8	0.15	0.25	2,400	35,000	0.07	0.15	1,600	30,000	0.05	0.1	1,400	25,000	0.03	0.07	1,000	20,000
		10	0.15	0.2	2,000	30,000	0.07	0.1	1,200	30,000	0.05	0.07	1,000	25,000	0.03	0.05	800	20,000
		20	0.03	0.05	800	18,000	0.02	0.04	600	16,000	0.012	0.025	450	16,000	0.008	0.015	360	14,000
		25	0.02	0.04	540	18,000	0.01	0.03	450	16,000	0.01	0.02	360	16,000	0.007	0.01	300	14,000
		30	0.01	0.03	360	14,000	0.007	0.02	320	14,000	0.005	0.01	240	14,000	0.003	0.005	200	12,000
	1°	10	0.15	0.25	2,000	30,000	0.1	0.2	1,800	25,000	0.05	0.2	1,400	25,000	0.05	0.1	1,000	20,000
		15	0.08	0.15	1,600	25,000	0.05	0.1	1,200	20,000	0.03	0.1	920	20,000	0.02	0.05	780	18,000
		20	0.05	0.1	1,000	20,000	0.03	0.07	800	18,000	0.02	0.05	600	18,000	0.015	0.03	550	16,000
		25	0.03	0.05	700	18,000	0.02	0.04	550	16,000	0.012	0.025	400	16,000	0.008	0.015	350	14,000
		30	0.02	0.04	450	16,000	0.01	0.03	360	16,000	0.01	0.02	300	16,000	0.007	0.01	250	14,000
		10	0.15	0.25	2,000	30,000	0.1	0.2	2,000	25,000	0.05	0.2	1,600	25,000	0.05	0.1	1,200	20,000
	1°30'	15	0.08	0.15	1,800	25,000	0.05	0.1	1,400	20,000	0.03	0.1	920	20,000	0.02	0.05	780	18,000
		20	0.06	0.1	1,200	25,000	0.05	0.07	1,000	20,000	0.03	0.05	820	20,000	0.02	0.03	650	18,000
		10	0.2	0.3	2,000	30,000	0.1	0.2	2,000	25,000	0.05	0.2	1,600	25,000	0.05	0.1	1,200	20,000
		15	0.1	0.2	2,000	30,000	0.1	0.1	1,600	25,000	0.05	0.1	1,200	25,000	0.05	0.05	900	20,000
		20	0.07	0.12	1,400	25,000	0.05	0.1	1,200	20,000	0.03	0.1	900	20,000	0.02	0.05	750	18,000
		12	0.15	0.3	2,400	20,000	0.1	0.3	2,000	18,000	0.1	0.2	1,600	16,000	0.1	0.1	1,200	14,000
1	30'	16	0.1	0.2	1,800	18,000	0.07	0.15	1,600	16,000	0.05	0.08	1,200	14,000	0.03	0.07	800	12,000
		20	0.07	0.12	1,600	16,000	0.05	0.1	1,400	14,000	0.03	0.06	1,000	12,000	0.02	0.04	700	10,000
		25	0.05	0.1	1,000	14,000	0.03	0.08	850	14,000	0.02	0.05	700	12,000	0.02	0.02	600	10,000
		30	0.03	0.08	800	12,000	0.03	0.05	700	12,000	0.02	0.03	540	10,000	0.01	0.02	420	8,500
		35	0.03	0.05	600	12,000	0.025	0.04	500	12,000	0.015	0.025	420	10,000	0.008	0.015	320	8,500
		40	0.02	0.04	420	12,000	0.02	0.03	360	12,000	0.01	0.02	300	10,000	0.008	0.01	240	8,500
	1°	50	0.01	0.03	300	10,000	0.01	0.02	240	10,000	0.005	0.01	200	8,500	0.005	0.005	160	7,000
		12	0.15	0.3	2,400	20,000	0.15	0.3	2,000	18,000	0.1	0.2	1,600	16,000	0.1	0.1	1,200	14,000
		16	0.12	0.2	1,800	18,000	0.1	0.15	1,600	16,000	0.1	0.1	1,400	14,000	0.05	0.1	900	12,000
		20	0.1	0.15	1,600	18,000	0.07	0.1	1,400	16,000	0.05	0.08	1,200	14,000	0.03	0.05	800	12,000
1°30'	25	0.07	0.12	1,400	14,000	0.05	0.1	1,200	14,000	0.03	0.05	1,000	12,000	0.02	0.03	700	10,000	
	30	0.05	0.1	1,000	14,000	0.035	0.08	850	14,000	0.025	0.05	700	12,000	0.02	0.02	600	10,000	
	35	0.05	0.1	800	12,000	0.035	0.06	700	12,000	0.02	0.05	600	10,000	0.015	0.02	500	8,500	
	40	0.03	0.05	700	12,000	0.03	0.05	600	12,000	0.02	0.04	540	10,000	0.01	0.02	400	8,500	
	50	0.025	0.04	420	12,000	0.02	0.03	360	12,000	0.01	0.02	300	10,000	0.008	0.01	240	8,500	
	12	0.2	0.35	2,400	20,000	0.15	0.35	2,000	18,000	0.12	0.2	1,600	16,000	0.1	0.15	1,200	14,000	
	16	0.15	0.2	1,800	18,000	0.1	0.2	1,600	16,000	0.1	0.15	1,400	14,000	0.05	0.1	1,000	12,000	
	20	0.1	0.2	1,800	18,000	0.07	0.15	1,600	16,000	0.05	0.1	1,200	14,000	0.03	0.1	900	12,000	
25	0.1	0.15	1,600	16,000	0.07	0.12	1,400	16,000	0.05	0.08	1,200	14,000	0.03	0.07	900	12,000		
30	0.07	0.12	1,400	14,000	0.05	0.1	1,200	14,000	0.03	0.06	1,000	12,000	0.02	0.03	850	10,000		
35	0.06	0.12	1,000	14,000	0.05	0.1	900	14,000	0.03	0.05	800	12,000	0.02	0.03	700	10,000		

アブリハードン鋼 P
Prehardened Steel

ステンレス鋼 M
Stainless Steel

チタン合金 耐熱合金 S
Titanium Alloy Heat Resistant Alloy

~55 HRC 高硬度鋼 H
~65 HRC Hardened Steel

コーティング
Coating
ロングネック
Long Neck
テーパードネック
Tapered Neck

切削条件参考表

Recommended Milling Conditions

被削材 Work Material			調質鋼 Prehardened Steels HPM・NAK (~41HRC)				高硬度鋼 Hardened Steels STAVAX・SKD61 (~52HRC)				高硬度鋼 Hardened Steels SKD11・PD613 (~62HRC)				ハイス High Speed Steels SKH・HAP (~65HRC)			
Rサイズ Radius	首角 Neck Taper Angle	首下長 Under Neck Length	切込み量 Depth of Cut		送り速度 Feed	回転数 Spindle Speed	切込み量 Depth of Cut		送り速度 Feed	回転数 Spindle Speed	切込み量 Depth of Cut		送り速度 Feed	回転数 Spindle Speed	切込み量 Depth of Cut		送り速度 Feed	回転数 Spindle Speed
			ap mm	ae mm	mm/min	min ⁻¹	ap mm	ae mm	mm/min	min ⁻¹	ap mm	ae mm	mm/min	min ⁻¹	ap mm	ae mm	mm/min	min ⁻¹
1	1°30'	40	0.05	0.1	900	14,000	0.03	0.08	800	14,000	0.02	0.05	700	12,000	0.02	0.02	600	10,000
		50	0.04	0.07	800	12,000	0.03	0.05	700	12,000	0.02	0.04	600	10,000	0.01	0.02	420	8,500
	2°	12	0.2	0.4	2,400	20,000	0.2	0.3	2,000	20,000	0.15	0.25	1,600	18,000	0.1	0.2	1,200	16,000
		16	0.15	0.3	2,400	20,000	0.1	0.3	2,000	18,000	0.1	0.2	1,600	16,000	0.1	0.1	1,200	14,000
		20	0.12	0.2	2,000	18,000	0.1	0.2	1,800	16,000	0.1	0.1	1,400	14,000	0.05	0.1	1,100	12,000
		25	0.1	0.2	1,800	16,000	0.07	0.15	1,600	16,000	0.05	0.1	1,200	14,000	0.03	0.07	1,000	12,000
		30	0.1	0.15	1,600	16,000	0.07	0.15	1,400	16,000	0.05	0.08	1,100	14,000	0.03	0.07	900	12,000
		40	0.07	0.12	1,400	14,000	0.05	0.1	1,200	14,000	0.03	0.05	1,000	12,000	0.02	0.03	800	10,000
	50	0.05	0.12	1,000	14,000	0.05	0.1	900	14,000	0.03	0.05	800	12,000	0.02	0.03	600	10,000	
	1.5	30°	15	0.2	0.4	2,400	18,000	0.1	0.4	2,000	18,000	0.1	0.3	1,600	14,000	0.1	0.2	1,200
20			0.15	0.3	2,000	18,000	0.1	0.3	1,600	18,000	0.1	0.2	1,400	14,000	0.08	0.1	1,000	12,000
25			0.12	0.3	1,800	16,000	0.1	0.25	1,400	16,000	0.07	0.15	1,200	12,000	0.05	0.07	900	10,000
30			0.12	0.25	1,200	16,000	0.08	0.2	1,200	14,000	0.05	0.1	1,000	12,000	0.035	0.06	700	10,000
40			0.07	0.15	800	14,000	0.04	0.1	720	12,000	0.025	0.06	600	10,000	0.02	0.04	480	8,000
50			0.05	0.1	600	12,000	0.025	0.04	540	10,000	0.015	0.02	480	7,000	0.01	0.02	360	5,000
1°		15	0.2	0.5	2,400	20,000	0.15	0.5	2,000	20,000	0.15	0.4	1,600	18,000	0.1	0.3	1,400	14,000
		20	0.15	0.4	2,000	18,000	0.1	0.4	1,800	18,000	0.1	0.2	1,400	16,000	0.08	0.2	1,200	12,000
		25	0.15	0.3	1,800	18,000	0.1	0.3	1,600	16,000	0.1	0.15	1,200	12,000	0.06	0.1	1,000	10,000
		30	0.12	0.3	1,600	16,000	0.08	0.2	1,200	14,000	0.05	0.1	1,000	12,000	0.035	0.07	700	10,000
		40	0.07	0.15	1,000	16,000	0.04	0.1	800	12,000	0.03	0.06	600	10,000	0.02	0.04	500	8,000
		50	0.05	0.12	700	12,000	0.025	0.04	580	10,000	0.015	0.02	480	7,000	0.01	0.02	360	5,000
1°30'		15	0.25	0.5	3,000	20,000	0.2	0.5	2,400	20,000	0.2	0.4	2,000	18,000	0.15	0.3	1,400	14,000
		20	0.15	0.4	2,400	18,000	0.1	0.4	2,000	18,000	0.1	0.3	1,600	16,000	0.1	0.2	1,200	12,000
		25	0.15	0.3	2,000	18,000	0.1	0.3	1,600	18,000	0.1	0.2	1,400	16,000	0.1	0.1	1,000	12,000
		30	0.12	0.3	1,800	16,000	0.1	0.25	1,400	16,000	0.07	0.15	1,200	14,000	0.05	0.07	900	10,000
		40	0.1	0.25	1,200	16,000	0.06	0.2	1,000	14,000	0.04	0.1	800	12,000	0.03	0.05	520	10,000
		50	0.07	0.15	800	12,000	0.035	0.1	600	10,000	0.02	0.07	500	8,000	0.02	0.05	400	6,000
2°	15	0.25	0.6	3,000	20,000	0.2	0.6	2,400	20,000	0.2	0.4	2,000	18,000	0.15	0.3	1,600	14,000	
	20	0.2	0.5	2,400	18,000	0.15	0.4	2,000	18,000	0.12	0.3	1,600	16,000	0.1	0.2	1,200	12,000	
	30	0.2	0.4	2,000	16,000	0.15	0.3	1,800	16,000	0.1	0.2	1,400	14,000	0.07	0.12	1,000	12,000	
2	1°	20	0.5	1.5	3,000	18,000	0.4	1	2,400	18,000	0.2	0.8	2,000	16,000	0.15	0.6	1,600	12,000
		30	0.3	1	2,400	16,000	0.2	0.7	1,600	14,000	0.1	0.3	1,200	12,000	0.06	0.15	1,000	10,000
		40	0.2	0.3	2,000	12,000	0.1	0.15	1,200	9,000	0.06	0.1	1,000	6,000	0.035	0.07	800	5,000
		50	0.1	0.2	1,600	10,000	0.07	0.1	900	7,000	0.04	0.07	750	5,000	0.02	0.05	550	4,000
		61.1	0.05	0.1	1,200	8,000	0.025	0.04	600	5,000	0.015	0.025	480	3,500	0.01	0.02	360	3,000

備考
Notes

- ※1 切削条件参考表は、等高線荒取りの条件を示します。
 ※2 切込み量の、apは軸方向の切込み深さ、aeはピックフィードを示します。
 ※3 びびりが発生する場合は、回転数と送り速度を同じ割合で下げて下さい。また、主軸回転数が足りない場合も同様に同じ割合で下げて下さい。
 ※4 深い部分を加工する際は、クーラントの給油および切りくずの排出に十分注意して下さい。
 ※5 オイルミストクーラントをお奨めします。
 ※6 切込み量、機械剛性により条件が異なります。その都度調整して下さい。
 ※1 Above conditions are for contour line roughing process.
 ※2 Depth of Cut : ap=Axial Depth of Cut / ae=Radial Depth of Cut.
 ※3 Reduce both spindle speed and feed at same rate for chattering and also for insufficient spindle speed of a machine.
 ※4 Coolant supply and chip disposal in the deep portion are very important.
 ※5 Recommended oil mist coolant.
 ※6 Adjust milling conditions according to the volume of Depth of Cut and rigidity of machine.

P プリハードン鋼
Prehardened SteelM ステンレス鋼
Stainless SteelS チタン合金
耐熱合金
Titanium Alloy
Heat Resistant AlloyH 高硬度鋼
Hardened Steel
~55 HRC
~65 HRCコーティング
Coating
ボール
Ball
チップ
Chip

MRBTNH345

サイズ R0.5 × 首角30' ~ R2 × 首角1°
Size R0.5 × neck taper angle30' ~ R2 × neck taper angle1°



レギュラーライン
無限プレミアム
ロングネックタイプ

Regular Line
MUGEN PREMIUM
Long Neck Type

無限コーティングプレミアム ロングテーパネック3枚刃ボールエンドミル

MUGEN COATING PREMIUM 3-Flute Long Taper Neck Ball End Mill

3枚刃強ねじれとテーパネックの採用で深部の加工を高能率に

3-flute with high helix angle and taper neck design for deep area milling with high efficiency

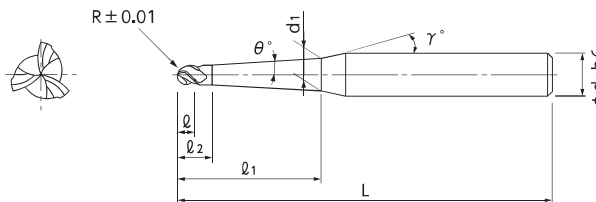

- 首下部をテーパにし、従来のロングネックタイプよりも剛性を向上。
- 耐熱性に優れた無限コーティングプレミアムを採用し、高硬度鋼加工においても長寿命。
- NS独自の3枚刃形状の採用で高能率加工が可能。
- Higher rigidity brought by taper neck than existing long neck.
- MUGEN COATING PREMIUM because of high heat resistance, realized long tool life for hardened steels.
- High effective machining achieved by NS original 3-flute design.

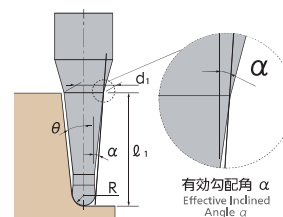

★ 再研磨可能 (シャンク長15mm以上のもの。詳細はお問い合わせください。)

単位 [寸法: mm / 価格: 円]
Unit [Size: mm / Retail Price: JPY]

コードNo. Code No.	(R)ボール半径 Radius	(θ)首角 Neck Taper Angle	(ℓ ₁)首下長 Under Neck Length	(d ₁)首元径 Neck Dia.	(ℓ)刃長 Length of Cut	(ℓ ₂)首下長2 Under Neck Length	(γ)首角2 Neck Taper Angle 2	(α)有効勾配角 Effective Inclined Angle	(d)シャンク径 Shank Dia.	(L)全長 Overall Length	標準価格 Retail Price
08-00590-05020	R0.5	30'	12	1.11	0.75	1.25	12°	0°15'	6	60	7,400
08-00590-05021			16	1.18	0.75	1.25	12°	0°19'	6	60	7,400
08-00590-05022			20	1.25	0.75	1.25	12°	0°21'	6	70	9,400
08-00590-05023			25	1.34	0.75	1.25	12°	0°23'	6	70	9,900
08-00590-05024			30	1.42	0.75	1.25	12°	0°24'	6	70	10,400
08-00590-05030		1°	12	1.30	0.75	1.25	12°	0°42'	6	60	7,400
08-00590-05031			16	1.44	0.75	1.25	12°	0°46'	6	60	7,400
08-00590-05032			20	1.58	0.75	1.25	12°	0°49'	6	70	9,400
08-00590-05033			25	1.75	0.75	1.25	12°	0°51'	6	70	9,900
08-00590-05034			30	1.93	0.75	1.25	12°	0°53'	6	70	10,400
08-00590-05040		1°30'	12	1.48	0.75	1.25	12°	1°09'	6	60	7,400
08-00590-05041			16	1.69	0.75	1.25	12°	1°14'	6	60	7,400
08-00590-05042	20		1.90	0.75	1.25	12°	1°17'	6	70	9,400	
08-00590-05043	25		2.17	0.75	1.25	12°	1°20'	6	70	9,900	
08-00590-05044	30		2.43	0.75	1.25	12°	1°21'	6	70	10,400	
08-00590-05050	2°	20	2.23	0.75	1.25	12°	1°45'	6	70	9,400	
08-00590-05051		30	2.93	0.75	1.25	12°	1°50'	6	70	10,400	
08-00590-07520	R0.75	30'	12	1.58	1.1	1.85	12°	0°12'	6	60	7,800
08-00590-07521			16	1.65	1.1	1.85	12°	0°16'	6	60	8,500
08-00590-07523			20	1.72	1.1	1.85	12°	0°19'	6	70	8,500
08-00590-07524			25	1.81	1.1	1.85	12°	0°21'	6	70	9,200
08-00590-07525			30	1.90	1.1	1.85	12°	0°22'	6	70	9,200
08-00590-07530		1°	12	1.76	1.1	1.85	12°	0°37'	6	60	7,800
08-00590-07531			16	1.90	1.1	1.85	12°	0°43'	6	60	8,500
08-00590-07532			20	2.04	1.1	1.85	12°	0°46'	6	70	8,500
08-00590-07533			25	2.22	1.1	1.85	12°	0°49'	6	70	9,200
08-00590-07534			30	2.39	1.1	1.85	12°	0°51'	6	70	9,200
08-00590-07540		1°30'	20	2.36	1.1	1.85	12°	1°13'	6	70	8,500
08-00590-07541			30	2.88	1.1	1.85	12°	1°19'	6	70	9,200
08-00590-07552	2°	30	3.37	1.1	1.85	12°	1°47'	6	70	9,200	

オーダー方法
How to Order

MRBTNH345 ボール半径(R) × 首角(θ) × 首下長(ℓ₁)を指示してください。
When you order, indicate MRBTNH345 (R) × (θ) × (ℓ₁).

※(γ)は参考値です。
※(γ) is reference value.

加工事例
Machining case

W-015
W-016

無限コーティングプレミアム ロングテーパネック3枚刃ボールエンドミル

MUGEN COATING PREMIUM 3-Flute Long Taper Neck Ball End Mill

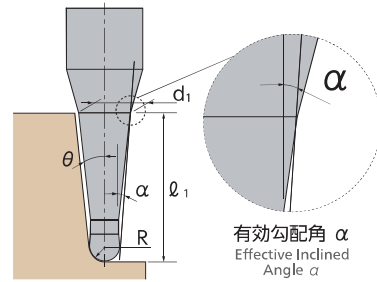

コードNo. Code No.	(R)ボール半径 Radius	(θ)首角 Neck Taper Angle	(ℓ ₁)首下長 Under Neck Length	(d ₁)首元径 Neck Dia.	(ℓ)刃長 Length of Cut	(ℓ ₂)首下長2 Under Neck Length	(γ)首角2 Neck Taper Angle 2	(α)有効勾配角 Effective Inclined Angle	(d)シャック径 Shank Dia.	(L)全長 Overall Length	標準価格 Retail Price	
★ 08-00590-10020	R1	30°	12	2.06	1.5	2.5	12°	0°8′	6	60	7,800	
★ 08-00590-10021			16	2.13	1.5	2.5	12°	0°13′	6	60	8,000	
★ 08-00590-10022			20	2.20	1.5	2.5	12°	0°16′	6	70	8,500	
★ 08-00590-10023			25	2.28	1.5	2.5	12°	0°19′	6	70	9,400	
★ 08-00590-10024			30	2.37	1.5	2.5	12°	0°21′	6	70	10,400	
★ 08-00590-10025			40	2.54	1.5	2.5	12°	0°23′	6	80	12,200	
★ 08-00590-10030		1°	12	2.22	1.5	2.5	12°	0°31′	6	60	7,800	
★ 08-00590-10031			16	2.36	1.5	2.5	12°	0°38′	6	60	8,000	
★ 08-00590-10032			20	2.50	1.5	2.5	12°	0°43′	6	70	8,500	
★ 08-00590-10033			25	2.68	1.5	2.5	12°	0°46′	6	70	9,400	
★ 08-00590-10034			30	2.85	1.5	2.5	12°	0°48′	6	70	10,400	
★ 08-00590-10035			40	3.20	1.5	2.5	12°	0°51′	6	80	12,900	
★ 08-00590-10040		1°30′	20	2.81	1.5	2.5	12°	1°09′	6	70	8,500	
★ 08-00590-10041			25	3.07	1.5	2.5	12°	1°13′	6	70	10,200	
★ 08-00590-10042			30	3.33	1.5	2.5	12°	1°16′	6	70	11,700	
★ 08-00590-10043			40	3.85	1.5	2.5	12°	1°19′	6	80	13,000	
★ 08-00590-10050		2°	20	3.11	1.5	2.5	12°	1°35′	6	70	8,500	
★ 08-00590-10051			25	3.46	1.5	2.5	12°	1°40′	6	70	10,200	
★ 08-00590-10052			30	3.81	1.5	2.5	12°	1°43′	6	70	11,700	
★ 08-00590-10053			40	4.51	1.5	2.5	12°	1°47′	6	80	13,000	
★ 08-00590-15020		R1.5	30°	15	3.16	4.5	6	12°	0°18′	6	70	9,400
★ 08-00590-15021				20	3.24	4.5	6	12°	0°21′	6	70	9,600
★ 08-00590-15022				25	3.33	4.5	6	12°	0°22′	6	70	10,200
★ 08-00590-15023				30	3.42	4.5	6	12°	0°24′	6	70	11,700
★ 08-00590-15024				40	3.59	4.5	6	12°	0°25′	6	80	13,000
★ 08-00590-15030			1°	15	3.31	4.5	6	12°	0°36′	6	70	9,400
★ 08-00590-15031				20	3.49	4.5	6	12°	0°42′	6	70	9,600
★ 08-00590-15032				25	3.66	4.5	6	12°	0°45′	6	70	10,200
★ 08-00590-15033				30	3.84	4.5	6	12°	0°48′	6	70	11,700
★ 08-00590-15034			40	4.19	4.5	6	12°	0°51′	6	80	13,000	
★ 08-00590-15040	1°30′		30	4.26	4.5	6	12°	1°12′	6	70	11,700	
★ 08-00590-15041			40	4.78	4.5	6	12°	1°16′	6	80	13,000	
★ 08-00590-15042			50	5.30	4.5	6	12°	1°19′	6	100	15,100	
★ 08-00590-15050	2°		30	4.68	4.5	6	12°	1°36′	6	70	11,700	
★ 08-00590-15051			40	5.37	4.5	6	12°	1°42′	6	80	13,000	
★ 08-00590-20031	R2		1°	30	4.77	6	8	12°	0°44′	6	80	11,700
★ 08-00590-20032				40	5.12	6	8	12°	0°48′	6	80	14,700
★ 08-00590-20033				50	5.47	6	8	12°	0°50′	6	100	17,500
★ 08-00590-20034		65.2		-	6	8	-	0°53′	6	110	18,800	

P プリハードン鋼
Prehardened Steel

M ステンレス鋼
Stainless Steel

S チタン合金
耐熱合金
Titanium Alloy
Heat Resistant Alloy

H ハードコート
高硬度鋼
Hardened Steel
~55 HRC
~65 HRC

コーティング
Coating
ボールエンドミル
Ball End Mill
テーパネック
Taper Neck

MRBTN345

切削条件参考表

Recommended Milling Conditions

被削材 Work Material			高硬度鋼 Hardened Steels SKD61・STAVAX (~52HRC)				高硬度鋼 Hardened Steels SKD11 (~62HRC)			
Rサイズ Radius	首角 Neck Taper Angle	首下長 Under Neck Length	切込み量 Depth of Cut		送り速度 Feed	回転数 Spindle Speed	切込み量 Depth of Cut		送り速度 Feed	回転数 Spindle Speed
			a _p mm	a _e mm	mm/min	min ⁻¹	a _p mm	a _e mm	mm/min	min ⁻¹
0.5	30°	12	0.02	0.1	1,000	16,000	0.01	0.07	800	14,000
		16	0.01	0.1	600	12,000	0.005	0.07	500	10,000
		20	0.01	0.07	400	10,000	0.005	0.05	300	8,000
		25	0.005	0.05	300	8,000	0.003	0.03	250	6,000
		30	0.005	0.02	200	6,000	0.003	0.01	150	4,000
	1°	12	0.03	0.15	1,200	16,000	0.02	0.1	1,000	14,000
		16	0.02	0.15	700	12,000	0.01	0.1	600	10,000
		20	0.02	0.1	500	10,000	0.01	0.08	400	8,000
		25	0.01	0.08	400	8,000	0.008	0.06	300	6,000
	1°30'	12	0.03	0.15	1,200	16,000	0.02	0.1	1,000	14,000
		16	0.02	0.15	700	12,000	0.01	0.1	600	10,000
		20	0.02	0.1	500	10,000	0.01	0.08	400	8,000
2°	20	0.03	0.2	700	12,000	0.02	0.15	600	10,000	
	30	0.02	0.1	500	8,000	0.01	0.08	400	6,000	
0.75	30°	12	0.06	0.2	1,500	18,000	0.04	0.15	1,200	16,000
		16	0.04	0.2	1,200	16,000	0.02	0.15	950	14,000
		20	0.02	0.1	700	12,000	0.015	0.07	600	10,000
		25	0.01	0.1	500	9,000	0.01	0.07	350	7,000
		30	0.01	0.05	300	7,000	0.01	0.04	200	5,000
	1°	12	0.06	0.2	1,500	18,000	0.05	0.15	1,300	16,000
		16	0.04	0.2	1,200	16,000	0.04	0.15	1,000	14,000
		20	0.04	0.15	700	12,000	0.04	0.1	700	10,000
		25	0.03	0.15	600	9,000	0.01	0.1	400	7,000
	1°30'	20	0.05	0.2	800	12,000	0.04	0.15	800	10,000
		30	0.03	0.1	400	7,000	0.02	0.1	350	5,000
	2°	30	0.04	0.2	500	7,000	0.03	0.15	400	6,000
30		0.04	0.2	500	7,000	0.03	0.15	400	6,000	
1	30°	12	0.1	0.3	1,500	16,000	0.08	0.2	1,400	14,000
		16	0.1	0.3	1,200	12,000	0.08	0.2	1,000	10,000
		20	0.07	0.25	800	10,000	0.05	0.2	600	8,000
		25	0.07	0.2	600	8,500	0.05	0.15	500	6,500
		30	0.04	0.1	400	7,000	0.02	0.07	300	5,000
		40	0.02	0.07	300	5,000	0.01	0.05	200	4,000
	1°	12	0.1	0.3	1,500	16,000	0.08	0.25	1,400	14,000
		16	0.1	0.3	1,200	12,000	0.08	0.25	1,000	10,000
		20	0.08	0.25	1,000	10,000	0.06	0.2	800	8,000
		25	0.08	0.2	800	8,500	0.06	0.15	600	6,500
		30	0.07	0.15	600	7,000	0.04	0.1	400	5,000
	1°30'	20	0.08	0.3	1,000	10,000	0.06	0.25	800	8,000
25		0.08	0.2	800	8,500	0.06	0.15	600	6,500	
30		0.07	0.15	600	7,000	0.04	0.1	400	5,000	
40		0.04	0.08	400	5,000	0.02	0.06	300	4,000	

プリハードン鋼 P
Prehardened Steel
 ステンレス鋼 M
Stainless Steel

チタン合金 S
耐熱合金
Titanium Alloy
Heat Resistant Alloy

~55 HRC
高硬度鋼 H
~65 HRC
Hardened Steel

コーティング
Long Neck
テーパネック
ボールネック

切削条件参考表

Recommended Milling Conditions

被削材 Work Material			高硬度鋼 Hardened Steels SKD61・STAVAX (~52HRC)				高硬度鋼 Hardened Steels SKD11 (~62HRC)				
Rサイズ Radius	首角 Neck Taper Angle	首下長 Under Neck Length	切込み量 Depth of Cut		送り速度 Feed	回転数 Spindle Speed	切込み量 Depth of Cut		送り速度 Feed	回転数 Spindle Speed	
			ap mm	ae mm	mm/min	min ⁻¹	ap mm	ae mm	mm/min	min ⁻¹	
1	2°	20	0.1	0.35	1,200	10,000	0.08	0.25	1,000	8,000	
		25	0.1	0.3	1,000	8,000	0.08	0.2	800	6,500	
		30	0.08	0.25	800	6,000	0.06	0.15	600	5,000	
		40	0.05	0.1	500	4,000	0.03	0.08	400	4,000	
1.5	30'	15	0.2	0.4	2,000	18,000	0.1	0.3	1,600	15,000	
		20	0.1	0.3	1,500	14,000	0.07	0.2	1,200	12,000	
		25	0.1	0.3	1,200	12,000	0.07	0.2	1,000	10,000	
		30	0.07	0.2	1,000	8,500	0.05	0.1	700	7,000	
		40	0.05	0.2	600	6,000	0.02	0.1	400	4,200	
	1°	15	0.2	0.4	2,000	18,000	0.1	0.3	1,600	15,000	
		20	0.1	0.3	1,500	16,000	0.08	0.2	1,200	12,000	
		25	0.1	0.3	1,200	14,000	0.08	0.2	1,000	10,000	
		30	0.08	0.2	1,000	10,000	0.06	0.15	800	7,000	
	1°30'	30	0.08	0.2	1,000	12,000	0.06	0.15	800	7,000	
		40	0.07	0.1	700	8,000	0.04	0.08	500	4,200	
		50	0.05	0.1	400	6,000	0.03	0.08	300	3,500	
	2°	30	0.1	0.3	1,500	12,000	0.08	0.3	1,200	10,000	
		40	0.08	0.2	800	8,000	0.06	0.2	600	7,000	
	2	1°	30	0.3	0.5	1,500	8,500	0.2	0.4	1,200	7,000
			40	0.2	0.5	1,200	6,000	0.1	0.4	1,000	5,000
50			0.1	0.3	700	5,000	0.05	0.2	600	4,000	
65.2			0.07	0.2	400	4,000	0.03	0.1	300	3,000	
備考 Notes			<p>※ 1 びびりが発生する場合は、回転数と送り速度を同じ割合で下げてください。また、主軸回転数が足りない場合も同様に同じ割合で下げてください。</p> <p>※ 2 深い部分を加工する際は、クーラントの給油および切りくずの排出性に十分注意してください。</p> <p>※ 3 オイルミストクーラントをお奨めします。</p> <p>※ 4 切込み量、機械剛性により条件が異なることがあります。その都度調整してください。</p> <p>※ 1 Reduce both spindle speed and feed at same rate for chattering and also for insufficient spindle speed of a machine.</p> <p>※ 2 Coolant supply and chip disposal are important for machining deep-rib.</p> <p>※ 3 We recommend using oil mist coolant.</p> <p>※ 4 Adjust milling conditions according to the volume of depth of cut and rigidity of machine.</p>								

P プリハードン鋼
Prehardened Steel

M ステンレス鋼
Stainless Steel

S チタン合金
耐熱合金
Titanium Alloy
Heat Resistant Alloy

H 高硬度鋼
Hardened Steel
~55 HRC
~65 HRC

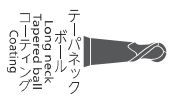

MHRH230R

サイズ

Size $\phi 0.2 \times R0.02 \sim \phi 0.9 \times R0.1$



無限コーティングプレミアム 高硬度用2枚刃ロングネックラジアスエンドミル

MUGEN COATING PREMIUM 2-Flute Long Neck Radius End Mill for Hardened Steel

調質鋼・高硬度鋼 (～65HRC) 対応の ロングネックラジアスエンドミル。L/Dは最大約16倍

Long neck corner radius end mill
for prehardened steels and hardened steels($\leq 65\text{HRC}$). Maximum L/D=16

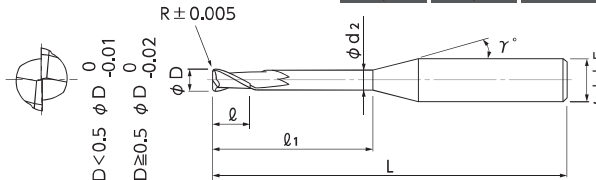
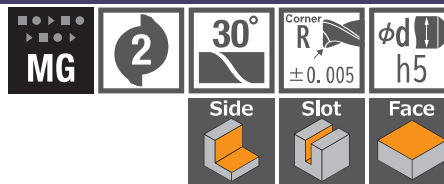

- 高硬度鋼用の無限コーティングプレミアムと新形状の採用で耐チップング性に優れ、びびりを抑えることにより仕上げ面が向上。
- 全97サイズ。
- MUGEN COATING PREMIUM for hardened steels and unique new design excel in chipping prevention and resolve chattering to realize excellent finished surface.
- Total 97 sizes.

【首部形状について】

表記の首角(γ)は目安になります。被削材との干渉が心配される時は、必ず実測での確認をお願いします。

【Neck Shape】

(γ) is reference value. Tool measurement required in order to avoid interference to the work material.

単位 [寸法: mm / 価格: JPY]
Unit [Size: mm / Retail Price: JPY]

コードNo. Code No.	(D)外径 Dia.	(R)コーナ半径 Corner Radius	(ℓ1)首下長 Under Neck Length	(ℓ)刃長 Length of Cut	(d2)首下径 Neck Dia.	(γ)首角 Neck Taper Angle	(d)シャンク径 Shank Dia.	(L)全長 Overall Length	標準価格 Retail Price	ワーク勾配角に対する実有効長 Actual effective length depending on inclined angle of workpiece.									
										30°	1°	1°30′	2°	3°					
08-00227-02021	0.2	R0.02	0.5	0.15	0.18	12°	4	45	10,100	0.56	0.59	0.62	0.65	0.71					
08-00227-02023			1					45	10,100	1.09	1.13	1.19	1.24	1.38					
08-00227-02025			1.5					45	11,900	1.61	1.68	1.76	1.84	2.04					
08-00227-02027			2					45	13,000	2.13	2.22	2.33	2.44	2.71					
08-00227-02051			0.5					45	10,100	0.56	0.59	0.61	0.64	0.70					
08-00227-02053		1	45					10,100	1.08	1.13	1.18	1.24	1.37						
08-00227-02055		1.5	45					11,900	1.61	1.68	1.75	1.84	2.03						
08-00227-02057		2	45					13,000	2.13	2.22	2.32	2.43	2.70						
08-00227-03021		0.3	R0.02					1	0.25	0.28	12°	4	45	9,800	1.09	1.13	1.19	1.24	1.38
08-00227-03022								1.5					45	9,800	1.61	1.68	1.76	1.84	2.04
08-00227-03023	2			45	9,800	2.13	2.22	2.33					2.44	2.71					
08-00227-03024	2.5			45	12,300	2.65	2.77	2.90					3.04	3.37					
08-00227-03025	3			45	12,300	3.17	3.31	3.47					3.64	4.03					
08-00227-03051	1		45	9,800	1.08	1.13	1.18	1.24					1.37						
08-00227-03052	1.5		45	9,800	1.61	1.68	1.75	1.84					2.03						
08-00227-03053	2		45	9,800	2.13	2.22	2.32	2.43					2.70						
08-00227-03054	2.5		45	12,300	2.65	2.77	2.89	3.03					3.36						
08-00227-03055	3		45	12,300	3.17	3.31	3.46	3.63					4.02						
08-00227-04021	0.4	R0.02	1	0.3	0.37	12°	4	45	6,500	1.11	1.16	1.21	1.27	1.41					
08-00227-04022			1.5					45	6,500	1.63	1.70	1.78	1.87	2.07					
08-00227-04023			2					45	6,500	2.15	2.25	2.35	2.47	2.74					
08-00227-04024			2.5					45	6,500	2.67	2.79	2.92	3.07	3.40					
08-00227-04025			3					45	6,500	3.20	3.34	3.49	3.67	4.06					
08-00227-04027		4	45					6,500	4.24	4.43	4.63	4.86	5.39						
08-00227-04051		1	45					6,500	1.11	1.16	1.21	1.27	1.40						
08-00227-04052		1.5	45					6,500	1.63	1.70	1.78	1.86	2.06						
08-00227-04053		2	45					6,500	2.15	2.25	2.35	2.46	2.73						
08-00227-04054		2.5	45					6,500	2.67	2.79	2.92	3.06	3.39						
08-00227-04055	3	45	6,500	3.19	3.34	3.49	3.66	4.05											
08-00227-04057	4	45	6,500	4.24	4.43	4.63	4.86	5.38											
08-00227-04101	R0.1	1	45	6,500	1.11	1.15	1.20	1.26	1.38										
08-00227-04103		2	45	6,500	2.15	2.24	2.34	2.45	2.71										
08-00227-04105		3	45	6,500	3.19	3.33	3.48	3.65	4.04										
08-00227-04107		4	45	6,500	4.24	4.42	4.62	4.85	5.36										
08-00227-05021		1	45	5,300	1.14	1.19	1.24	1.30	1.44										
08-00227-05022	2	45	5,300	2.18	2.27	2.38	2.50	2.77											
08-00227-05023	R0.02	3	45	5,300	3.22	3.36	3.52	3.69	4.10										
08-00227-05024		4	45	5,300	4.26	4.45	4.66	4.89	5.42										
08-00227-05025		5	45	5,300	5.31	5.54	5.80	6.09	6.75										
08-00227-05026		6	45	5,300	6.35	6.63	6.94	7.28	8.08										
08-00227-05051		1	45	5,300	1.13	1.18	1.24	1.29	1.43										
08-00227-05052	2	45	5,300	2.18	2.27	2.38	2.49	2.76											
08-00227-05053	R0.05	3	45	5,300	3.22	3.36	3.52	3.69	4.09										
08-00227-05054		4	45	5,300	4.26	4.45	4.66	4.88	5.41										
08-00227-05055		5	45	5,300	5.31	5.54	5.80	6.08	6.74										
08-00227-05056		6	45	5,300	6.35	6.63	6.94	7.28	8.07										

オーダー方法
How to Order

MHRH230R 外径(D) × コーナ半径(R) × 首下長(ℓ1)を指示してください。
When you order, indicate MHRH230R (D) × (R) × (ℓ1).

無限コーティングプレミアム 高硬度用2枚刃ロングネックラジアスエンドミル

MUGEN COATING PREMIUM 2-Flute Long Neck Radius End Mill for Hardened Steel

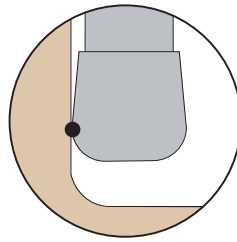

点切削のためびびらない！
Suppress chattering by point milling

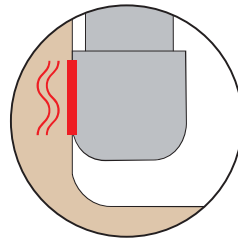

一般的なエンドミル
General End Mill

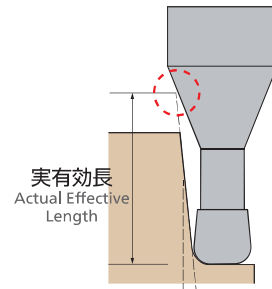

実有効長
Actual Effective Length
ワーク勾配角
Inclined Angle

P プリハードン鋼
Prehardened Steel

M ステンレス鋼
Stainless Steel

コードNo. Code No.	(D)外径 Dia.	(R)コーナ半径 Corner Radius	(d1)首下長 Under Neck Length	(L)刃長 Length of Cut	(d2)首下径 Neck Dia.	(γ)首角 Neck Taper Angle	(d)シャック径 Shank Dia.	(L)全長 Overall Length	標準価格 Retail Price	ワーク勾配角に対する実有効長 Actual effective length depending on inclined angle of workpiece.				
										30°	1°	1°30'	2°	3°
08-00227-05101	0.5	R0.1	1	0.4	0.46	12°	4	45	5,300	1.13	1.18	1.23	1.28	1.41
08-00227-05102			2					45	5,300	2.17	2.27	2.37	2.48	2.74
08-00227-05103			3					45	5,300	3.22	3.36	3.51	3.68	4.07
08-00227-05104			4					45	5,300	4.26	4.45	4.65	4.87	5.40
08-00227-05105			5					45	5,300	5.30	5.54	5.79	6.07	6.72
08-00227-05106			6					45	5,300	6.35	6.63	6.93	7.27	8.05
08-00227-06021	0.6	R0.02	2	0.5	0.56	12°	4	45	5,700	2.18	2.27	2.38	2.50	2.77
08-00227-06023			4					45	5,700	4.26	4.45	4.66	4.89	5.42
08-00227-06025			6					45	5,700	6.35	6.63	6.94	7.28	8.08
08-00227-06027			8					50	5,900	8.43	8.81	9.22	9.68	10.73
08-00227-06029		10	50					5,900	10.52	10.99	11.50	12.07	13.39	
08-00227-06051		R0.05	2					45	5,700	2.18	2.27	2.38	2.49	2.76
08-00227-06053			4					45	5,700	4.26	4.45	4.66	4.88	5.41
08-00227-06055			6					45	5,700	6.35	6.63	6.94	7.28	8.07
08-00227-06057			8					50	5,900	8.43	8.81	9.22	9.67	10.72
08-00227-06059			10					50	5,900	10.52	10.99	11.50	12.06	13.38
08-00227-06101	R0.1		2	45	5,300	2.17	2.27	2.37	2.48	2.74				
08-00227-06103		4	45	5,300	4.26	4.45	4.65	4.87	5.40					
08-00227-06105		6	45	5,300	6.35	6.63	6.93	7.27	8.05					
08-00227-06107		8	50	5,500	8.43	8.80	9.21	9.66	10.71					
08-00227-06109	10	50	5,500	10.52	10.98	11.49	12.05	13.36						
08-00227-07020	0.7	R0.02	2	0.55	0.66	12°	4	45	6,000	2.18	2.27	2.38	2.50	2.77
08-00227-07021			4					45	6,000	4.26	4.45	4.66	4.89	5.42
08-00227-07023			6					45	6,000	6.35	6.63	6.94	7.28	8.08
08-00227-07050		R0.05	2					45	6,000	2.18	2.27	2.38	2.49	2.76
08-00227-07051			4					45	6,000	4.26	4.45	4.66	4.88	5.41
08-00227-07053			6					45	6,000	6.35	6.63	6.94	7.28	8.07
08-00227-07100		R0.1	2					45	6,000	2.17	2.27	2.37	2.48	2.74
08-00227-07101			4					45	6,000	4.26	4.45	4.65	4.87	5.40
08-00227-07103			6					45	6,000	6.35	6.63	6.93	7.27	8.05
08-00227-07109			10					45	6,000	10.52	10.98	11.49	12.05	13.36
08-00227-08020	0.8	R0.02	2	0.65	0.76	12°	4	45	6,000	2.18	2.27	2.38	2.50	2.77
08-00227-08021			4					45	6,000	4.26	4.45	4.66	4.89	5.42
08-00227-08023			6					45	6,000	6.35	6.63	6.94	7.28	8.08
08-00227-08025			8					50	6,200	8.43	8.81	9.22	9.68	10.73
08-00227-08050		R0.05	2					45	6,000	2.18	2.27	2.38	2.49	2.76
08-00227-08051			4					45	6,000	4.26	4.45	4.66	4.88	5.41
08-00227-08053			6					45	6,000	6.35	6.63	6.94	7.28	8.07
08-00227-08055			8					50	6,200	8.43	8.81	9.22	9.67	10.72
08-00227-08059			12					50	6,200	12.60	13.17	13.78	14.46	16.03
08-00227-08100			R0.1					2	45	6,000	2.17	2.27	2.37	2.48
08-00227-08101		4						45	6,000	4.26	4.45	4.65	4.87	5.40
08-00227-08103		6						45	6,000	6.35	6.63	6.93	7.27	8.05
08-00227-08105		8						50	6,200	8.43	8.80	9.21	9.66	10.71
08-00227-08109		12	50					6,200	12.60	13.16	13.77	14.45	16.01	
08-00227-08200		R0.2	2					45	6,000	2.17	2.26	2.36	2.46	2.71
08-00227-08201			4					45	6,000	4.26	4.44	4.64	4.85	5.36
08-00227-08203			6					45	6,000	6.34	6.62	6.92	7.25	8.02
08-00227-08205			8					50	6,200	8.43	8.80	9.20	9.64	10.67
08-00227-08209			12					50	6,200	12.60	13.15	13.76	14.43	15.98
08-00227-09101			0.9					R0.1	4	45	6,800	4.28	4.47	4.68
08-00227-09105	8			50	6,800	8.46	8.83		9.24	9.69	10.74			

S チタン合金
耐熱合金
Titanium Alloy
Heat Resistant Alloy

H 高硬度鋼
Hardened Steel
~55 HRC
~65 HRC

コーティング
Coating
ロングネック
Long Neck
ラジアス
Radius
エンドミル
End Mill

MHRH230R

切削条件参考表

Recommended Milling Conditions

被削材 Work Material			調質鋼 Prehardened Steels HPM・NAK (~42HRC)				高硬度鋼 Hardened Steels HPM38・STAVAX・SKD61 (~55HRC)				高硬度鋼 Hardened Steels SKD11・PD613 (~62HRC)				ハイス High Speed Steels SKH (~65HRC)				
外径 Dia.	コーナ 半径 Corner Radius	首下長 Under Neck Length	回転数	送り速度	切込み量		回転数	送り速度	切込み量		回転数	送り速度	切込み量		回転数	送り速度	切込み量		
			min ⁻¹	mm/min	a _p mm	a _e mm	min ⁻¹	mm/min	a _p mm	a _e mm	min ⁻¹	mm/min	a _p mm	a _e mm	min ⁻¹	mm/min	a _p mm	a _e mm	
0.2	0.02	0.5	30,000	240	0.005	0.05	30,000	200	0.003	0.04	30,000	160	0.003	0.02	30,000	120	0.003	0.01	
		1	30,000	180	0.005	0.05	30,000	150	0.003	0.04	30,000	120	0.002	0.02	30,000	80	0.002	0.01	
		1.5	30,000	120	0.004	0.05	30,000	100	0.002	0.04	30,000	80	0.002	0.02	30,000	60	0.001	0.01	
		2	30,000	70	0.003	0.05	30,000	50	0.002	0.04	30,000	40	0.001	0.02	30,000	30	0.001	0.01	
	0.05	0.5	30,000	240	0.01	0.05	30,000	200	0.003	0.04	30,000	160	0.003	0.02	30,000	120	0.003	0.01	
		1	30,000	180	0.007	0.05	30,000	150	0.003	0.04	30,000	120	0.003	0.02	30,000	80	0.003	0.01	
		1.5	30,000	120	0.005	0.05	30,000	100	0.002	0.04	30,000	80	0.002	0.02	30,000	60	0.002	0.01	
		2	30,000	70	0.003	0.05	30,000	50	0.002	0.04	30,000	40	0.002	0.02	30,000	30	0.002	0.01	
	0.3	0.02	1	30,000	350	0.015	0.1	30,000	300	0.003	0.08	30,000	250	0.003	0.04	30,000	200	0.003	0.03
			1.5	30,000	240	0.01	0.1	30,000	200	0.003	0.08	30,000	160	0.003	0.04	30,000	120	0.003	0.03
			2	30,000	180	0.007	0.1	30,000	150	0.003	0.08	30,000	120	0.003	0.04	25,000	100	0.003	0.03
			2.5	30,000	150	0.005	0.1	25,000	100	0.002	0.08	25,000	80	0.002	0.04	20,000	60	0.002	0.03
0.05		1	30,000	350	0.02	0.1	30,000	300	0.003	0.08	30,000	250	0.003	0.04	30,000	200	0.003	0.03	
		1.5	30,000	240	0.015	0.1	30,000	200	0.003	0.08	30,000	160	0.003	0.04	30,000	120	0.003	0.03	
		2	30,000	180	0.01	0.1	30,000	150	0.003	0.08	30,000	120	0.003	0.04	25,000	100	0.003	0.03	
		2.5	30,000	150	0.007	0.1	25,000	100	0.002	0.08	25,000	80	0.002	0.04	20,000	60	0.002	0.03	
0.4		0.02	1	30,000	450	0.015	0.12	30,000	400	0.005	0.1	28,000	350	0.005	0.05	25,000	300	0.004	0.04
			1.5	30,000	400	0.012	0.12	30,000	350	0.005	0.1	28,000	300	0.005	0.05	25,000	260	0.004	0.04
			2	30,000	360	0.01	0.12	30,000	300	0.005	0.1	25,000	250	0.005	0.05	25,000	220	0.003	0.04
			2.5	30,000	340	0.008	0.12	28,000	280	0.004	0.1	25,000	240	0.004	0.05	20,000	180	0.003	0.04
	0.05	1	30,000	450	0.025	0.12	30,000	400	0.005	0.1	28,000	350	0.005	0.05	25,000	300	0.005	0.04	
		1.5	30,000	400	0.022	0.12	30,000	350	0.005	0.1	28,000	300	0.005	0.05	25,000	260	0.005	0.04	
		2	30,000	360	0.02	0.12	30,000	300	0.005	0.1	25,000	250	0.005	0.05	25,000	220	0.005	0.04	
		2.5	30,000	340	0.015	0.12	28,000	280	0.004	0.1	25,000	240	0.004	0.05	20,000	180	0.004	0.04	
	0.1	1	30,000	320	0.015	0.12	25,000	250	0.004	0.1	23,000	220	0.003	0.05	18,000	160	0.003	0.04	
		2	30,000	250	0.006	0.12	25,000	200	0.003	0.1	20,000	160	0.002	0.05	18,000	120	0.002	0.04	
		3	30,000	250	0.006	0.12	25,000	200	0.003	0.1	20,000	160	0.002	0.05	18,000	120	0.002	0.04	
		4	30,000	250	0.01	0.12	25,000	200	0.003	0.1	20,000	160	0.002	0.05	18,000	120	0.002	0.04	
0.5	0.02	1	30,000	600	0.016	0.14	25,000	500	0.008	0.15	23,000	450	0.006	0.1	20,000	400	0.004	0.08	
		2	30,000	500	0.014	0.14	25,000	420	0.007	0.15	23,000	360	0.005	0.1	20,000	300	0.003	0.08	
		3	30,000	420	0.012	0.14	25,000	350	0.006	0.15	23,000	320	0.004	0.1	20,000	280	0.003	0.08	
		4	25,000	380	0.01	0.14	25,000	300	0.004	0.15	23,000	240	0.002	0.1	20,000	180	0.002	0.08	
		5	25,000	300	0.008	0.14	20,000	200	0.003	0.15	18,000	150	0.002	0.1	16,000	100	0.002	0.08	
		6	25,000	250	0.004	0.14	20,000	160	0.002	0.15	18,000	100	0.001	0.1	16,000	70	0.001	0.08	
	0.05	1	30,000	600	0.03	0.14	25,000	500	0.01	0.15	23,000	450	0.007	0.1	20,000	400	0.005	0.08	
		2	30,000	500	0.025	0.14	25,000	420	0.01	0.15	23,000	360	0.007	0.1	20,000	300	0.005	0.08	
		3	30,000	420	0.02	0.14	25,000	350	0.008	0.15	23,000	320	0.005	0.1	20,000	280	0.003	0.08	
		4	25,000	380	0.015	0.14	25,000	300	0.005	0.15	23,000	240	0.003	0.1	20,000	180	0.002	0.08	
		5	25,000	300	0.01	0.14	20,000	200	0.004	0.15	18,000	150	0.003	0.1	16,000	100	0.002	0.08	
		6	25,000	250	0.008	0.14	20,000	160	0.003	0.15	18,000	100	0.002	0.1	16,000	70	0.001	0.08	

プリハードン鋼 P
 Prehardened Steel

ステンレス鋼 M
 Stainless Steel

チタン合金 S
 Titanium Alloy
 耐熱合金
 Heat Resistant Alloy

高硬度鋼 H
 Hardened Steel

コーティング
 Coating
 Long neck
 Corner radius
 Long neck
 Corner radius
 Long neck
 Corner radius

切削条件参考表 Recommended Milling Conditions

被削材 Work Material			調質鋼 Prehardened Steels HPM・NAK (~42HRC)				高硬度鋼 Hardened Steels HPM38・STAVAX・SKD61 (~55HRC)				高硬度鋼 Hardened Steels SKD11・PD613 (~62HRC)				ハイス High Speed Steels SKH (~65HRC)							
外径 Dia.	コーナ 半径 Corner Radius	首下長 Under Neck Length	回転数 Spindle Speed		送り速度 Feed		切込み量 Depth of Cut		回転数 Spindle Speed		送り速度 Feed		切込み量 Depth of Cut		回転数 Spindle Speed		送り速度 Feed		切込み量 Depth of Cut			
			min ⁻¹	mm/min	ap mm	ae mm	min ⁻¹	mm/min	ap mm	ae mm	min ⁻¹	mm/min	ap mm	ae mm	min ⁻¹	mm/min	ap mm	ae mm	min ⁻¹	mm/min	ap mm	ae mm
0.6	0.02	2	30,000	600	0.016	0.2	25,000	500	0.012	0.2	23,000	400	0.006	0.15	20,000	320	0.004	0.1				
		4	25,000	450	0.012	0.2	23,000	400	0.007	0.2	20,000	300	0.004	0.15	18,000	200	0.003	0.1				
		6	23,000	300	0.008	0.2	20,000	200	0.005	0.2	18,000	150	0.003	0.15	12,000	100	0.002	0.1				
		8	18,000	200	0.006	0.2	16,000	150	0.003	0.2	14,000	100	0.001	0.15	10,000	80	0.001	0.1				
		10	16,000	120	0.003	0.2	14,000	100	0.001	0.2	12,000	80	0.001	0.15	8,000	50	0.001	0.1				
	0.05 0.1	2	30,000	600	0.035	0.2	25,000	500	0.02	0.2	23,000	400	0.01	0.15	20,000	320	0.007	0.1				
		4	25,000	450	0.025	0.2	23,000	400	0.015	0.2	20,000	300	0.007	0.15	18,000	200	0.005	0.1				
		6	23,000	300	0.015	0.2	20,000	200	0.008	0.2	18,000	150	0.005	0.15	12,000	100	0.003	0.1				
		8	18,000	200	0.01	0.2	16,000	150	0.005	0.2	14,000	100	0.002	0.15	10,000	80	0.001	0.1				
		10	16,000	120	0.005	0.2	14,000	100	0.002	0.2	12,000	80	0.001	0.15	8,000	50	0.001	0.1				
0.7	0.02	2	30,000	900	0.016	0.25	25,000	700	0.012	0.25	23,000	600	0.006	0.15	20,000	450	0.003	0.12				
		4	28,000	700	0.012	0.25	25,000	600	0.008	0.25	23,000	500	0.005	0.15	20,000	350	0.002	0.12				
		6	25,000	500	0.008	0.25	20,000	350	0.005	0.25	18,000	250	0.003	0.15	16,000	200	0.002	0.12				
	0.05 0.1	2	30,000	900	0.04	0.25	25,000	700	0.03	0.25	23,000	600	0.015	0.15	20,000	450	0.01	0.12				
		4	28,000	700	0.03	0.25	25,000	600	0.02	0.25	23,000	500	0.01	0.15	20,000	350	0.007	0.12				
		6	25,000	500	0.02	0.25	20,000	350	0.01	0.25	18,000	250	0.007	0.15	16,000	200	0.005	0.12				
0.8	0.02	2	28,000	1,000	0.016	0.3	25,000	800	0.014	0.25	23,000	700	0.006	0.16	20,000	500	0.005	0.14				
		4	28,000	900	0.012	0.3	25,000	700	0.008	0.25	23,000	600	0.005	0.16	20,000	400	0.003	0.14				
		6	23,000	700	0.009	0.3	20,000	550	0.006	0.25	18,000	450	0.004	0.16	16,000	320	0.002	0.14				
		8	18,000	500	0.006	0.3	16,000	400	0.003	0.25	14,000	300	0.002	0.16	12,000	200	0.002	0.14				
	0.05 0.1 0.2	2	28,000	1,000	0.05	0.3	25,000	800	0.03	0.25	23,000	700	0.02	0.16	20,000	500	0.015	0.14				
		4	28,000	900	0.045	0.3	25,000	700	0.025	0.25	23,000	600	0.015	0.16	20,000	400	0.01	0.14				
		6	23,000	700	0.03	0.3	20,000	550	0.02	0.25	18,000	450	0.01	0.16	16,000	320	0.007	0.14				
		8	18,000	500	0.02	0.3	16,000	400	0.01	0.25	14,000	300	0.005	0.16	12,000	200	0.005	0.14				
		12	16,000	300	0.007	0.3	14,000	200	0.005	0.25	12,000	120	0.003	0.16	10,000	80	0.001	0.14				
		0.9	0.1	4	25,000	1,100	0.05	0.3	25,000	850	0.03	0.3	20,000	700	0.02	0.2	18,000	600	0.01	0.15		
8	18,000			500	0.03	0.3	16,000	400	0.01	0.3	14,000	350	0.008	0.2	10,000	250	0.005	0.15				
備考 Notes			<p>※1 実際の加工形状および使用機械等にて切削条件を調整してください。 ※2 切込み量のapは軸方向の切込み深さ、aeは半径方向の切込み深さを示します。 ※3 高硬度鋼を切削加工する場合は、オイルミストクーラントをお奨めします。 ※4 Z切込み時のアプローチ方法として、ヘリカル（螺旋）及びランプ（傾斜）での切削加工をお奨めします。 ※5 L（首下長）/D（外径）が8倍を超える場合は立ち壁付近の送り速度を50%以下、切込み量：aeを30%以下に調整してください。 ※6 溝切削は、切削条件表を参考に切込み量：ap及び送り速度を50%以下に設定し、往復切削をお奨めします。 ※7 びびりが発生する場合は、回転数と送り速度を同じ割合で下げてください。また、主軸回転数が足りない場合も同様に同じ割合で下げてください。</p> <p>※1 Adjust milling conditions according to milling shape and machine type. ※2 ap : Axial Depth of Cut, ae : Radial Depth of Cut. ※3 Recommend to use oil mist coolant for machining hardened steels. ※4 Recommend to apply helical or ramping for approaching into axial direction. ※5 Adjust feed rate 50% lower and cutting depth (ae) 30% lower for milling deep wall area when L/D exceeds 8 for stable milling. ※6 For slotting, recommend reciprocating milling by adjusting feed & ap in below 50% of recommended milling condition. ※7 Reduce both spindle speed and feed at same rate for chattering and also for insufficient spindle speed of a machine.</p>																			

P プリハードン鋼
Prehardened Steel

M ステンレス鋼
Stainless Steel

S チタン合金
耐熱合金
Titanium Alloy
Heat Resistant Alloy

H 高硬度鋼
Hardened Steel
~55 HRC
~65 HRC



MHRH430R

規格追加
Lineup Expansion

サイズ

Size $\phi 0.1 \times R0.01 \sim \phi 6 \times R1$

∞ Premium

≤65 HRC

無限コーティングプレミアム 高硬度用4枚刃ロングネックラジアスエンドミル

MUGEN COATING PREMIUM 4-Flute Long Neck Radius End Mill for Hardened Steel

調質鋼・高硬度鋼（～65HRC）対応の 4枚刃ロングネックラジアスエンドミル。L/Dは最大約16倍

4-flute long neck corner radius end mill for prehardened steels and hardened steels(～65HRC). Maximum L/D=16

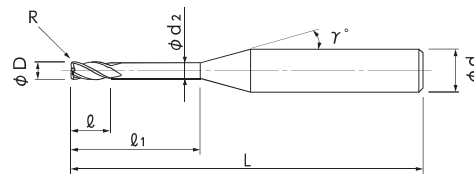
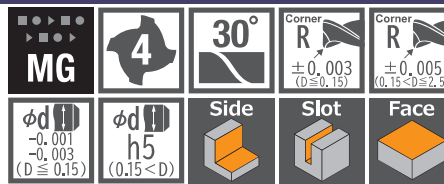

- 高硬度鋼用の無限コーティングプレミアムと新形状の採用で耐チップング性に優れ、びびりを抑えることにより仕上げ面が向上。
- 高能率加工が可能な4枚刃タイプ。
- 全336サイズ。
- MUGEN COATING PREMIUM for hardened steels and unique new design excel in chipping prevention and resolve chattering to realize excellent finished surface.
- 4 flutes end mill for higher efficiency.
- Total 336 sizes.

$\phi 0.1 \sim \phi 0.3$ の底刃は、軸中心まで刃がありません。削り残しにご注意ください。
Beware of stocks because there is no blade to the shaft center of end teeth of $\phi 0.1$ to $\phi 0.3$.

[首部形状について]

表記の首角(γ)は目安になります。被削材との干渉が心配される時は、必ず実測での確認をお願いします。

(Neck Shape)

(γ) is reference value. Tool measurement required in order to avoid interference to the work material.

サイズ Size	外径公差 Diameter Tolerance	コーナ半径公差 Corner R Tolerance	シャンク径公差 Shank Dia. Tolerance
$D \leq 0.15$	0 -0.007	± 0.003 ($0 \leq 0.15$)	-0.001* -0.003
$0.15 < D < 0.5$	0 -0.01	± 0.005	h5 ($0.15 < D$)
$0.5 \leq D \leq 2.5$	0 -0.02		
$D > 2.5$		± 0.01	

* $\phi 0.15$ 以下のシャンク径公差はJIS規格でh4に括れられますが、当社では-0.001mm～-0.003mmの範囲[0.002mm]で生産しております。
Shank tolerance is h4(JIS), NS TOOL produces within 0.002mm from -0.001mm～-0.003mm.

◆ NEWサイズ

★ 再研磨可能 (シャンク長15mm以上のもの。詳細はお問い合わせください。)

単位 [寸法: mm / 価格: 円] Unit [Size: mm / Retail Price: JPY]

コードNo. Code No.	(D)外径 Dia.	(R)コーナ半径 Corner Radius	(L1)首下長 Under Neck Length	(L2)刃長 Length of Cut	(d2)首下径 Neck Dia.	(γ)首角 Neck Taper Angle	(d)シャンク径 Shank Dia.	(L)全長 Overall Length	標準価格 Retail Price	ワーク勾配角に対する実有効長 Actual effective length depending on inclined angle of workpiece.																
										30°	1°	1°30'	2°	3°												
◆ 08-00237-01013	0.1	R0.01	0.3	0.08	0.085	12°	4	45	14,700	0.34	0.36	0.38	0.39	0.44												
◆ 08-00237-01015			0.5												0.55	0.58	0.60	0.63	0.70							
◆ 08-00237-01512	0.15	R0.01	0.3	0.12	0.135	12°	4	45	13,600	0.34	0.36	0.38	0.39	0.44												
◆ 08-00237-01513			0.5												0.55	0.58	0.60	0.63	0.70							
◆ 08-00237-01515			0.75												0.81	0.85	0.89	0.93	1.03							
◆ 08-00237-01517			1												1.07	1.12	1.17	1.23	1.37							
◆ 08-00237-01522			R0.02												0.3	0.34	0.36	0.37	0.39	0.43						
◆ 08-00237-01523		0.5													0.55	0.58	0.60	0.63	0.70							
◆ 08-00237-01525		0.75													0.81	0.85	0.89	0.93	1.03							
◆ 08-00237-01527		1													1.07	1.12	1.17	1.23	1.36							
08-00237-02021		0.2													R0.02	0.5	0.15	0.18	12°	4	45	13,600	0.56	0.59	0.62	0.65
08-00237-02023			1													1.09										
08-00237-02025	1.5		1.61	1.68	1.76	1.84	2.04																			
08-00237-02027	2		2.13	2.22	2.33	2.44	2.71																			
08-00237-02051	R0.05		0.5	0.56	0.59	0.61	0.64	0.70																		
08-00237-02053			1	1.08	1.13	1.18	1.24	1.37																		
08-00237-02055			1.5	1.61	1.68	1.75	1.84	2.03																		
08-00237-02057			2	2.13	2.22	2.32	2.43	2.70																		
08-00237-03021			0.3	R0.02	1	0.25	0.28	12°	4	45	13,200	1.09	1.13	1.19	1.24	1.38										
08-00237-03022	1.5				1.61																					
08-00237-03023	2	2.13			2.22												2.33	2.44	2.71							
08-00237-03024	2.5	2.65			2.77												2.90	3.04	3.37							
08-00237-03025	3	3.17			3.31												3.47	3.64	4.03							
08-00237-03051	R0.05	1			1.08												1.13	1.18	1.24	1.37						
08-00237-03052		1.5			1.61												1.68	1.75	1.84	2.03						
08-00237-03053		2			2.13												2.22	2.32	2.43	2.70						
08-00237-03054		2.5			2.65												2.77	2.89	3.03	3.36						
08-00237-03055		3			3.17												3.31	3.46	3.63	4.02						

オーダー方法
How to Order

MHRH430R 外径(D)×コーナ半径(R)×首下長(L1)を指示してください。
When you order, indicate MHRH430R (D)×(R)×(L1).

加工事例
Machining case

W-017

無限コーティングプレミアム 高硬度用4枚刃ロングネックラジアスエンドミル

MUGEN COATING PREMIUM 4-Flute Long Neck Radius End Mill for Hardened Steel

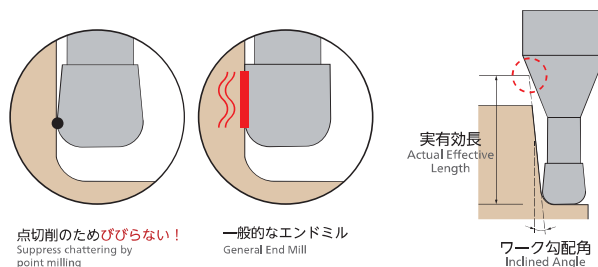

P プリハードン鋼
Prehardened Steel

M ステンレス鋼
Stainless Steel

コードNo. Code No.	(D)外径 Dia.	(R)コーナ半径 Corner Radius	(L1)首下長 Under Neck Length	(L)刃長 Length of Cut	(d2)首下径 Neck Dia.	(γ)首角 Neck Taper Angle	(d)シャンク径 Shank Dia.	(L)全長 Overall Length	標準価格 Retail Price	ワーク勾配角に対する実有効長 Actual effective length depending on inclined angle of workpiece.					
										30°	1°	1°30'	2°	3°	
08-00237-04021	0.4	R0.02	1	0.3	0.37	12°	4	45	8,800	1.11	1.16	1.21	1.27	1.41	
08-00237-04022			1.5					45	8,800	1.63	1.70	1.78	1.87	2.07	
08-00237-04023			2					45	8,800	2.15	2.25	2.35	2.47	2.74	
08-00237-04024			2.5					45	8,800	2.67	2.79	2.92	3.07	3.40	
08-00237-04025			3					45	8,800	3.20	3.34	3.49	3.67	4.06	
08-00237-04027			4					45	8,800	4.24	4.43	4.63	4.86	5.39	
08-00237-04051		R0.05	1					45	8,800	1.11	1.16	1.21	1.27	1.40	
08-00237-04052			1.5					45	8,800	1.63	1.70	1.78	1.86	2.06	
08-00237-04053			2					45	8,800	2.15	2.25	2.35	2.46	2.73	
08-00237-04054			2.5					45	8,800	2.67	2.79	2.92	3.06	3.39	
08-00237-04055			3					45	8,800	3.19	3.34	3.49	3.66	4.05	
08-00237-04057			4					45	8,800	4.24	4.43	4.63	4.86	5.38	
08-00237-04101		R0.1	1					45	8,800	1.11	1.15	1.20	1.26	1.38	
08-00237-04103			2					45	8,800	2.15	2.24	2.34	2.45	2.71	
08-00237-04105			3					45	8,800	3.19	3.33	3.48	3.65	4.04	
08-00237-04107			4					45	8,800	4.24	4.42	4.62	4.85	5.36	
08-00237-05021	0.5	R0.02	1	0.4	0.46	12°	4	45	7,200	1.14	1.19	1.24	1.30	1.44	
08-00237-05022			2					45	7,200	2.18	2.27	2.38	2.50	2.77	
08-00237-05023			3					45	7,200	3.22	3.36	3.52	3.69	4.10	
08-00237-05024			4					45	7,200	4.26	4.45	4.66	4.89	5.42	
08-00237-05025			5					45	7,200	5.31	5.54	5.80	6.09	6.75	
08-00237-05026			6					45	7,200	6.35	6.63	6.94	7.28	8.08	
08-00237-05051		R0.05	1					45	7,200	1.13	1.18	1.24	1.29	1.43	
08-00237-05052			2					45	7,200	2.18	2.27	2.38	2.49	2.76	
08-00237-05053			3					45	7,200	3.22	3.36	3.52	3.69	4.09	
08-00237-05054			4					45	7,200	4.26	4.45	4.66	4.88	5.41	
08-00237-05055			5					45	7,200	5.31	5.54	5.80	6.08	6.74	
08-00237-05056			6					45	7,200	6.35	6.63	6.94	7.28	8.07	
08-00237-05101		R0.1	1					45	7,200	1.13	1.18	1.23	1.28	1.41	
08-00237-05102			2					45	7,200	2.17	2.27	2.37	2.48	2.74	
08-00237-05103			3					45	7,200	3.22	3.36	3.51	3.68	4.07	
08-00237-05104			4					45	7,200	4.26	4.45	4.65	4.87	5.40	
08-00237-05105	5		45	7,200	5.30	5.54	5.79	6.07	6.72						
08-00237-05106	6		45	7,200	6.35	6.63	6.93	7.27	8.05						
08-00237-06021	0.6	R0.02	2	0.5	0.56	12°	4	45	7,700	2.18	2.27	2.38	2.50	2.77	
08-00237-06023			4					45	7,700	4.26	4.45	4.66	4.89	5.42	
08-00237-06025			6					45	7,700	6.35	6.63	6.94	7.28	8.08	
08-00237-06027			8					50	8,000	8.43	8.81	9.22	9.68	10.73	
08-00237-06029			10					50	8,000	10.52	10.99	11.50	12.07	13.39	
08-00237-06051			2					45	7,700	2.18	2.27	2.38	2.49	2.76	
08-00237-06053		R0.05	4					45	7,700	4.26	4.45	4.66	4.88	5.41	
08-00237-06055			6					45	7,700	6.35	6.63	6.94	7.28	8.07	
08-00237-06057			8					50	8,000	8.43	8.81	9.22	9.67	10.72	
08-00237-06059			10					50	8,000	10.52	10.99	11.50	12.06	13.38	
08-00237-06101			R0.1					2	45	7,200	2.17	2.27	2.37	2.48	2.74
08-00237-06103								4	45	7,200	4.26	4.45	4.65	4.87	5.40
08-00237-06105		6						45	7,200	6.35	6.63	6.93	7.27	8.05	
08-00237-06107		8						50	7,400	8.43	8.80	9.21	9.66	10.71	
08-00237-06109		10	50					7,400	10.52	10.98	11.49	12.05	13.36		
08-00237-07020		0.7	R0.02					2	0.55	0.66	12°	4	45	8,100	2.18
08-00237-07021	4			45	8,100	4.26	4.45	4.66					4.89	5.42	
08-00237-07023	6			45	8,100	6.35	6.63	6.94					7.28	8.08	
08-00237-07050	R0.05		2	45	8,100	2.18	2.27	2.38					2.49	2.76	
08-00237-07051			4	45	8,100	4.26	4.45	4.66					4.88	5.41	
08-00237-07053			6	45	8,100	6.35	6.63	6.94					7.28	8.07	
08-00237-07100			8	45	8,100	8.43	8.81	9.22					9.68	10.73	
08-00237-07101	R0.1		2	45	8,100	2.17	2.27	2.37					2.48	2.74	
08-00237-07103			4	45	8,100	4.26	4.45	4.65					4.87	5.40	
08-00237-07103			6	45	8,100	6.35	6.63	6.93					7.27	8.05	
08-00237-08020	0.8	R0.02	2	45	8,100	2.18	2.27	2.38	2.50	2.77					
08-00237-08021			4	45	8,100	4.26	4.45	4.66	4.89	5.42					
08-00237-08023			6	45	8,100	6.35	6.63	6.94	7.28	8.08					
08-00237-08025			8	50	8,400	8.43	8.81	9.22	9.68	10.73					

S チタン合金
耐熱合金
Titanium Alloy
Heat Resistant Alloy

H 高硬度鋼
Hardened Steel

~55 HRC

~65 HRC



MHRH430R

無限コーティングプレミアム 高硬度用4枚刃ロングネックラジアスエンドミル

MUGEN COATING PREMIUM 4-Flute Long Neck Radius End Mill for Hardened Steel

【首部形状について】

表記の首角(γ)は目安になります。被削材との干渉が心配される時は、必ず実測での確認をお願いします。

【Neck Shape】

(γ) is reference value. Tool measurement required in order to avoid interference to the work material.

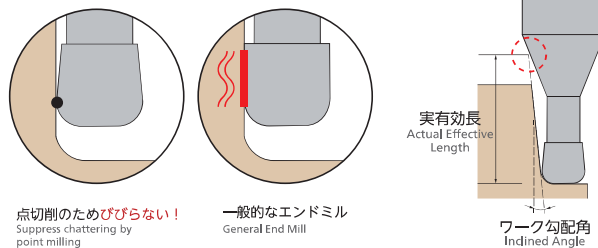

◆ NEWサイズ

★ 再研磨可能 (シャンク長15mm以上のもの。詳細はお問い合わせください。)

単位 [寸法: mm / 価格: JPY]

Unit [Size: mm / Retail Price: JPY]

コードNo. Code No.	(D)外径 Dia.	(R)コーナ半径 Corner Radius	(l1)首下長 Under Neck Length	(l)刃長 Length of Cut	(d2)首下径 Neck Dia.	(γ)首角 Neck Taper Angle	(d)シャンク径 Shank Dia.	(L)全長 Overall Length	標準価格 Retail Price	ワーク勾配角に対する実有効長 Actual effective length depending on inclined angle of workpiece.														
										30°	1°	1°30'	2°	3°										
08-00237-08050	0.8	R0.05	2	0.65	0.76	12°	4	45	8,100	2.18	2.27	2.38	2.49	2.76										
08-00237-08051			4					45	8,100	4.26	4.45	4.66	4.88	5.41										
08-00237-08053			6					45	8,100	6.35	6.63	6.94	7.28	8.07										
08-00237-08055			8					50	8,400	8.43	8.81	9.22	9.67	10.72										
08-00237-08059			12					50	8,400	12.60	13.17	13.78	14.46	16.03										
08-00237-08100			2					45	8,100	2.17	2.27	2.37	2.48	2.74										
08-00237-08101		4	45					8,100	4.26	4.45	4.65	4.87	5.40											
08-00237-08103		6	45					8,100	6.35	6.63	6.93	7.27	8.05											
08-00237-08105		8	50					8,400	8.43	8.80	9.21	9.66	10.71											
08-00237-08109		12	50					8,400	12.60	13.16	13.77	14.45	16.01											
08-00237-08200		2	R0.1					2	0.7	0.85	12°	4	45	8,100	2.17	2.26	2.36	2.46	2.71					
08-00237-08201		4						45					8,100	4.26	4.44	4.64	4.85	5.36						
08-00237-08203	6	45		8,100	6.34	6.62	6.92	7.25					8.02											
08-00237-08205	8	50		8,400	8.43	8.80	9.20	9.64					10.67											
08-00237-08209	12	50		8,400	12.60	13.15	13.76	14.43					15.98											
08-00237-09101	4	R0.2		4	0.8	0.95	12°	4					45	9,200	4.28	4.47	4.68	4.90	5.43					
08-00237-09105	8		50	9,200									8.46	8.83	9.24	9.69	10.74							
08-00237-10028	2		R0.02	2									0.8	0.95	12°	4	50	6,200	2.20	2.30	2.41	2.52	2.80	
08-00237-10020	3			50													6,200	3.25	3.39	3.55	3.72	4.13		
08-00237-10021	4			50													6,200	4.29	4.48	4.69	4.92	5.45		
08-00237-10022	5			50													6,800	5.33	5.57	5.83	6.11	6.78		
08-00237-10023	6	50		6,800													6.37	6.66	6.97	7.31	8.11			
08-00237-10025	8	50		6,800					8.46	8.84	9.25	9.70					10.76							
08-00237-10027	10	50	6,800	10.54					11.02	11.53	12.10	13.42												
08-00237-10058	2	R0.05	2	0.8					0.95	12°	4	50					6,200	2.20	2.30	2.40	2.52	2.79		
08-00237-10050	3		50									6,200					3.24	3.39	3.54	3.72	4.12			
08-00237-10051	4		50									6,200					4.29	4.48	4.68	4.91	5.44			
08-00237-10052	5		50		6,800	5.33	5.57	5.82				6.11					6.77							
08-00237-10053	6		50		6,800	6.37	6.66	6.97				7.31					8.10							
08-00237-10055	8		50		6,800	8.46	8.83	9.25				9.70	10.75											
08-00237-10057	10	50	6,800		10.54	11.01	11.53	12.09				13.41												
08-00237-10108	2	R0.1	2		0.8	0.95	12°	4				50	6,200	2.20	2.29	2.40	2.51	2.77						
08-00237-10100	3		50									6,200	3.24	3.38	3.54	3.71	4.10							
08-00237-10101	4		50									6,200	4.28	4.47	4.68	4.90	5.43							
08-00237-10102	5		50									6,800	5.33	5.56	5.82	6.10	6.75							
08-00237-10103	6		50									6,800	6.37	6.65	6.96	7.30	8.08							
08-00237-10105	8		50	6,800					8.46	8.83	9.24	9.69	10.74											
08-00237-10107	10	50	6,800	10.54					11.01	11.52	12.08	13.39												
08-00237-10208	2	R0.2	2	0.8					0.95	12°	4	50	6,200	2.19	2.28	2.38	2.49	2.74						
08-00237-10200	3		50									6,200	3.24	3.37	3.52	3.69	4.07							
08-00237-10201	4		50									6,200	4.28	4.46	4.66	4.88	5.39							
08-00237-10202	5		50									6,800	5.32	5.55	5.80	6.08	6.72							
08-00237-10203	6		50									6,800	6.37	6.64	6.94	7.28	8.05							
08-00237-10205	8		50		6,800	8.45	8.82	9.23				9.67	10.70											
08-00237-10207	10	50	6,800		10.54	11.00	11.51	12.06				13.36												
08-00237-10308	2	R0.3	2		0.8	0.95	12°	4				50	6,200	2.19	2.28	2.37	2.47	2.71						
08-00237-10300	3		50									6,200	3.23	3.36	3.51	3.67	4.03							
08-00237-10301	4		50									6,200	4.28	4.45	4.65	4.86	5.36							
08-00237-10302	5		50									6,800	5.32	5.54	5.79	6.06	6.69							
08-00237-10303	6		50									6,800	6.36	6.63	6.93	7.26	8.02							
08-00237-10305	8		50	6,800					8.45	8.81	9.21	9.65	10.67											
08-00237-10307	10	50	6,800	10.53					10.99	11.49	12.04	13.33												
08-00237-12101	5	R0.1	5	1					1.14	12°	4	50	7,000	5.35	5.59	5.84	6.13	6.79						
08-00237-12103	10		50									7,000	10.57	11.03	11.55	12.11	13.42							
08-00237-12201	5		R0.2									5	1	1.14	12°	4	50	7,000	5.35	5.58	5.83	6.11	6.75	
08-00237-12203	10											50					7,000	10.56	11.03	11.53	12.09	13.39		
08-00237-12301	5											R0.3					5	1	1.14	12°	4	50	7,000	5.34
08-00237-12303	10				50	7,000	10.56	11.02									11.52					12.07	13.36	

オーダー方法 How to Order

MHRH430R 外径(D) × コーナ半径(R) × 首下長(l1) を指示してください。

When you order, indicate MHRH430R (D) × (R) × (l1).

無限コーティングプレミアム 高硬度用4枚刃ロングネックラジアスエンドミル

MUGEN COATING PREMIUM 4-Flute Long Neck Radius End Mill for Hardened Steel

コードNo. Code No.	(D)外径 Dia.	(R)コーナー半径 Corner Radius	(ℓ)首下長 Under Neck Length	(ℓ)刃長 Length of Cut	(d)首下径 Neck Dia.	(γ)首角 Neck Taper Angle	(d)シャンク径 Shank Dia.	(L)全長 Overall Length	標準価格 Retail Price	ワーク勾配角に対する実有効長 Actual effective length depending on inclined angle of workpiece.										
										30°	1°	1°30'	2°	3°						
08-00237-15020	1.5	R0.02	3	1.2	1.43	12°	4	50	6,600	3.29	3.44	3.60	3.78	4.19						
08-00237-15021			4					50	6,600	4.34	4.53	4.74	4.97	5.52						
08-00237-15023			6					50	6,600	6.42	6.71	7.02	7.37	8.17						
08-00237-15025			8					50	7,000	8.51	8.89	9.30	9.76	10.82						
08-00237-15027			12					50	7,000	12.68	13.25	13.87	14.55	16.13						
08-00237-15029			15					50	7,000	15.81	16.51	17.29	18.14	20.12						
08-00237-15050			R0.05					3	50	6,600	3.29	3.44	3.60	3.77	4.18					
08-00237-15051								4	50	6,600	4.34	4.53	4.74	4.97	5.51					
08-00237-15053								6	50	6,600	6.42	6.71	7.02	7.36	8.16					
08-00237-15055								8	50	7,000	8.51	8.89	9.30	9.75	10.82					
08-00237-15057		12						50	7,000	12.68	13.24	13.86	14.54	16.12						
08-00237-15059		15						50	7,000	15.81	16.51	17.28	18.13	20.11						
08-00237-15100		R0.1						3	50	6,600	3.29	3.43	3.59	3.76	4.16					
08-00237-15101								4	50	6,600	4.33	4.52	4.73	4.96	5.49					
08-00237-15103								6	50	6,600	6.42	6.70	7.01	7.35	8.14					
08-00237-15105								8	50	7,000	8.50	8.88	9.29	9.75	10.80					
08-00237-15107			12					50	7,000	12.68	13.24	13.85	14.53	16.11						
08-00237-15109			15					50	7,000	15.80	16.51	17.28	18.12	20.09						
08-00237-15200			R0.2					3	50	6,600	3.29	3.42	3.58	3.74	4.13					
08-00237-15201								4	50	6,600	4.33	4.51	4.72	4.94	5.46					
08-00237-15203								6	50	6,600	6.42	6.69	7.00	7.33	8.11					
08-00237-15205								8	50	7,000	8.50	8.87	9.28	9.73	10.77					
08-00237-15207		12						50	7,000	12.67	13.23	13.84	14.51	16.08						
08-00237-15209		15						60	7,000	15.80	16.50	17.26	18.10	20.06						
08-00237-15300		R0.3						3	50	6,600	3.28	3.42	3.56	3.72	4.10					
08-00237-15301								4	50	6,600	4.33	4.51	4.70	4.92	5.42					
08-00237-15303								6	50	6,600	6.41	6.68	6.98	7.31	8.08					
08-00237-15305								8	50	7,000	8.50	8.86	9.26	9.71	10.73					
08-00237-15307			12					50	7,000	12.67	13.22	13.83	14.49	16.04						
08-00237-15309			15					60	7,000	15.80	16.49	17.25	18.08	20.02						
08-00237-15500			R0.5					3	50	6,600	3.27	3.40	3.53	3.68	4.03					
08-00237-15501								4	50	6,600	4.32	4.49	4.67	4.88	5.36					
08-00237-15503								6	50	6,600	6.40	6.67	6.96	7.27	8.01					
08-00237-15505								8	50	7,000	8.49	8.85	9.24	9.67	10.67					
08-00237-15507		12						50	7,000	12.66	13.20	13.80	14.45	15.98						
08-00237-15509		15						60	7,000	15.79	16.47	17.22	18.04	19.96						
08-00237-20020		2						R0.02	4	1.6	1.91	12°	4	50	6,600	4.39	4.58	4.80	5.03	5.58
08-00237-20021									6					50	6,600	6.47	6.76	7.08	7.42	8.23
08-00237-20023									8					50	7,000	8.56	8.94	9.36	9.82	10.89
08-00237-20025									12					50	7,000	12.73	13.30	13.92	14.60	16.20
08-00237-20027			16						60					7,000	16.90	17.66	18.48	19.39	21.51	
08-00237-20029			20						60					7,000	21.07	22.01	23.04	24.18	Free	
08-00237-20050			R0.05						4					50	6,600	4.38	4.58	4.79	5.02	5.57
08-00237-20051									6					50	6,600	6.47	6.76	7.07	7.42	8.22
08-00237-20053									8					50	7,000	8.56	8.94	9.35	9.81	10.88
08-00237-20055									12					50	7,000	12.73	13.29	13.92	14.60	16.19
08-00237-20057								16	60					7,000	16.90	17.65	18.48	19.38	21.50	
08-00237-20059								20	60					7,000	21.07	22.01	23.04	24.17	Free	
08-00237-20100								R0.1	4					50	6,600	4.38	4.57	4.78	5.02	5.55
08-00237-20101									6					50	6,600	6.47	6.75	7.07	7.41	8.21
08-00237-20103	8			50	7,000	8.55	8.93		9.35					9.80	10.86					
08-00237-20105	12			50	7,000	12.73	13.29		13.91					14.59	16.17					
08-00237-20107	16		60	7,000	16.90	17.65	18.47		19.37					21.48						
08-00237-20109	20		60	7,000	21.07	22.01	23.03		24.16					Free						
08-00237-20200	R0.2		4	50	6,600	4.38	4.57		4.77					5.00	5.52					
08-00237-20201			6	50	6,600	6.46	6.74		7.05					7.39	8.17					
08-00237-20203			8	50	7,000	8.55	8.92		9.33					9.78	10.83					
08-00237-20205			12	50	7,000	12.72	13.28		13.89					14.57	16.14					
08-00237-20207			16	60	7,000	16.89	17.64	18.46	19.35					21.45						
08-00237-20209			20	60	7,000	21.06	22.00	23.02	24.14					Free						
08-00237-20300			R0.3	4	50	6,600	4.37	4.56	4.76					4.98	5.49					
08-00237-20301				6	50	6,600	6.46	6.74	7.04					7.37	8.14					
08-00237-20303				8	50	7,000	8.55	8.91	9.32					9.76	10.80					
08-00237-20305				12	50	7,000	12.72	13.27	13.88					14.55	16.10					
08-00237-20307	16			60	7,000	16.89	17.63	18.44	19.33					21.41						
08-00237-20309	20			60	7,000	21.06	21.99	23.00	24.12					Free						
08-00237-20500	R0.5			4	50	6,600	4.37	4.54	4.73					4.94	5.42					
08-00237-20501				6	50	6,600	6.45	6.72	7.01					7.33	8.08					
08-00237-20503				8	50	7,000	8.54	8.90	9.29					9.72	10.73					
08-00237-20505				12	50	7,000	12.71	13.25	13.85					14.51	16.04					
08-00237-20507			16	60	7,000	16.88	17.61	18.41	19.30					21.35						
08-00237-20509			20	60	7,000	21.05	21.97	22.98	24.08					Free						

P プリハードン鋼
Prehardened Steel

M ステンレス鋼
Stainless Steel

S チタン合金
耐熱合金
Titanium Alloy
Heat Resistant Alloy

H 高硬度鋼
Hardened Steel
~ 55 HRC
~ 65 HRC



MHRH430R

無限コーティングプレミアム 高硬度用4枚刃ロングネックラジアスエンドミル

MUGEN COATING PREMIUM 4-Flute Long Neck Radius End Mill for Hardened Steel

【首部形状について】

表記の首角(γ)は目安になります。被削材との干渉が心配される時は、必ず実測での確認をお願いします。

【Neck Shape】

(γ) is reference value. Tool measurement required in order to avoid interference to the work material.

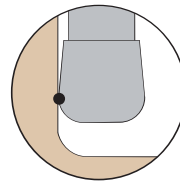

点切削のためびびらない!
Suppress chattering by
point milling

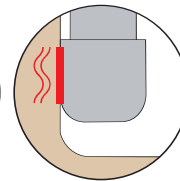

一般的なエンドミル
General End Mill

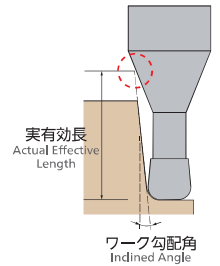

実有効長
Actual Effective
Length

ワーク勾配角
Inclined Angle

◆ Newサイズ

★ 再研磨可能 (シャンク長15mm以上のもの。詳細はお問い合わせください。)

単位 [寸法: mm / 価格: 円]
Unit [Size: mm / Retail Price: JPY]

コードNo. Code No.	(D)外径 Dia.	(R)コーナ半径 Corner Radius	(ℓ1)首下長 Under Neck Length	(ℓ)刃長 Length of Cut	(d2)首下径 Neck Dia.	(γ)首角 Neck Taper Angle	(d)シャンク径 Shank Dia.	(L)全長 Overall Length	標準価格 Retail Price	ワーク勾配角に対する実有効長 Actual effective length depending on inclined angle of workpiece.									
										30°	1°	1°30'	2°	3°					
08-00237-25101	2.5	R0.1	10	2	2.39	12°	4	50	7,200	10.69	11.16	11.68	12.25	13.58					
08-00237-25103			20					60	7,500	21.12	22.06	23.09	24.22	Free					
08-00237-25105			30					70	7,700	31.54	32.95	34.49	Free	Free					
08-00237-25201		R0.2	10					50	7,200	10.68	11.15	11.67	12.23	13.55					
08-00237-25203			20					60	7,500	21.11	22.05	23.07	24.20	Free					
08-00237-25205			30					70	7,700	31.54	32.94	34.48	Free	Free					
08-00237-25301		R0.3	10					50	7,200	10.68	11.14	11.65	12.21	13.51					
08-00237-25303			20					60	7,500	21.11	22.04	23.06	24.18	Free					
08-00237-25305			30					70	7,700	31.54	32.93	34.46	Free	Free					
08-00237-25501		R0.5	10					50	7,200	10.67	11.13	11.62	12.17	13.45					
08-00237-25503			20					60	7,500	21.10	22.02	23.03	24.14	Free					
08-00237-25505			30					70	7,700	31.53	32.92	34.43	Free	Free					
★ 08-00237-30058		3	R0.05					4	2.5	2.85	12°	6	50	6,000	4.53	4.73	4.95	5.19	5.76
★ 08-00237-30050								6					50	6,000	6.62	6.91	7.23	7.59	8.41
★ 08-00237-30051								8					50	6,000	8.70	9.09	9.51	9.98	11.06
★ 08-00237-30053	12		50	7,200	12.87	13.45	14.08	14.77					16.37						
★ 08-00237-30055	16		60	9,000	17.05	17.81	18.64	19.55					21.68						
★ 08-00237-30057	20		60	9,000	21.22	22.16	23.20	24.34					26.99						
★ 08-00237-30112	R0.1		4	50	6,000	4.53	4.73	4.95					5.18	5.74					
★ 08-00237-30100			6	50	6,000	6.62	6.91	7.23					7.58	8.39					
★ 08-00237-30101			8	50	6,000	8.70	9.09	9.51					9.97	11.05					
★ 08-00237-30103	R0.1		12	50	7,200	12.87	13.44	14.07					14.76	16.36					
★ 08-00237-30105			16	60	9,000	17.04	17.80	18.63					19.54	21.67					
★ 08-00237-30107			20	60	9,000	21.21	22.16	23.19					24.33	26.98					
★ 08-00237-30109	R0.2		25	70	9,000	26.43	27.61	28.90					30.31	Free					
★ 08-00237-30111			30	70	10,100	31.64	33.05	34.60					36.30	Free					
★ 08-00237-30212			4	50	6,000	4.53	4.72	4.93					5.16	5.71					
★ 08-00237-30200	R0.2		6	50	6,000	6.61	6.90	7.21					7.56	8.36					
★ 08-00237-30201			8	50	6,000	8.70	9.08	9.49					9.95	11.02					
★ 08-00237-30203			12	50	7,200	12.87	13.44	14.06					14.74	16.32					
★ 08-00237-30205	R0.2		16	60	9,000	17.04	17.79	18.62					19.52	21.63					
★ 08-00237-30207			20	60	9,000	21.21	22.15	23.18					24.31	26.94					
★ 08-00237-30209			25	70	9,000	26.42	27.60	28.88					30.29	Free					
★ 08-00237-30211	R0.3		30	70	10,100	31.64	33.05	34.58					36.28	Free					
★ 08-00237-30312			4	50	6,000	4.52	4.71	4.92					5.14	5.67					
★ 08-00237-30300			6	50	6,000	6.61	6.89	7.20					7.54	8.33					
★ 08-00237-30301	R0.3		8	50	6,000	8.69	9.07	9.48					9.93	10.98					
★ 08-00237-30303			12	50	7,200	12.86	13.43	14.04					14.72	16.29					
★ 08-00237-30305			16	60	9,000	17.04	17.78	18.60					19.50	21.60					
★ 08-00237-30307	R0.5		20	60	9,000	21.21	22.14	23.17					24.29	26.91					
★ 08-00237-30309			25	70	9,000	26.42	27.59	28.87					30.27	Free					
★ 08-00237-30311			30	70	10,100	31.63	33.04	34.57					36.26	Free					
★ 08-00237-30512	R0.5		4	50	6,000	4.51	4.69	4.89					5.11	5.61					
★ 08-00237-30500			6	50	6,000	6.60	6.87	7.17					7.50	8.26					
★ 08-00237-30501			8	50	6,000	8.68	9.05	9.45					9.89	10.92					
★ 08-00237-30503	R0.5		12	50	7,200	12.86	13.41	14.01					14.68	16.23					
★ 08-00237-30505			16	60	9,000	17.03	17.77	18.58					19.46	21.54					
★ 08-00237-30507			20	60	9,000	21.20	22.12	23.14					24.25	26.84					
★ 08-00237-30509	R1		25	70	9,000	26.41	27.57	28.84					30.23	Free					
★ 08-00237-30511			30	70	10,100	31.63	33.02	34.54					36.22	Free					
★ 08-00237-31001			8	50	6,000	8.66	9.01	9.38					9.79	10.75					
★ 08-00237-31003	R1		12	50	7,200	12.83	13.36	13.94					14.58	16.06					
★ 08-00237-31005			16	60	9,000	17.01	17.72	18.50					19.37	21.37					
★ 08-00237-31007			20	60	9,000	21.18	22.08	23.07					24.15	26.68					
★ 08-00237-31009	R1		25	70	9,000	26.39	27.53	28.77					30.14	33.32					
★ 08-00237-31011			30	70	10,100	31.60	32.97	34.47					36.12	Free					

オーダー方法 How to Order

MHRH430R 外径(D)×コーナ半径(R)×首下長(ℓ1)を指示してください。
When you order, indicate MHRH430R (D)×(R)×(ℓ1).

無限コーティングプレミアム 高硬度用4枚刃ロングネックラジアスエンドミル

MUGEN COATING PREMIUM 4-Flute Long Neck Radius End Mill for Hardened Steel

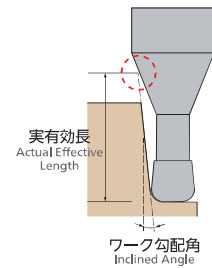
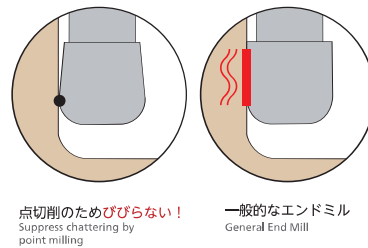

P プリハードン鋼 Prehardened Steel

M ステンレス鋼 Stainless Steel

コードNo. Code No.	(D)外径 Dia.	(R)コーナ半径 Corner Radius	(ℓ1)首下長 Under Neck Length	(ℓ)刃長 Length of Cut	(d2)首下径 Neck Dia.	(γ)首角 Neck Taper Angle	(d)シャンク径 Shank Dia.	(L)全長 Overall Length	標準価格 Retail Price	ワーク勾配角に対する実有効長 Actual effective length depending on inclined angle of workpiece.						
										30°	1°	1°30'	2°	3°		
										★08-00237-40106	4	R0.1	8	3.2	3.8	12°
★08-00237-40100	12	60	9,000	13.00	13.57	14.20	14.90	16.51								
★08-00237-40101	16	60	9,000	17.17	17.93	18.77	19.68	21.82								
★08-00237-40103	24	70	10,000	25.51	26.65	27.89	29.26	Free								
★08-00237-40105	32	70	10,000	33.85	35.36	37.01	Free	Free								
★08-00237-40206	8	R0.2	8	60	9,000	8.82	9.21	9.63	10.09	11.17						
★08-00237-40200	12		60	9,000	12.99	13.56	14.19	14.88	16.48							
★08-00237-40201	16		60	9,000	17.16	17.92	18.75	19.66	21.79							
★08-00237-40203	24		70	10,000	25.50	26.64	27.88	29.24	Free							
★08-00237-40205	32	70	10,000	33.85	35.35	37.00	Free	Free								
★08-00237-40306	8	R0.3	8	60	9,000	8.82	9.20	9.61	10.07	11.14						
★08-00237-40300	12		60	9,000	12.99	13.55	14.18	14.86	16.45							
★08-00237-40301	16		60	9,000	17.16	17.91	18.74	19.64	21.76							
★08-00237-40303	24		70	10,000	25.50	26.63	27.86	29.22	Free							
★08-00237-40305	32		70	10,000	33.84	35.34	36.99	Free	Free							
★08-00237-40506	8		R0.5	8	60	9,000	8.81	9.18	9.59	10.03		11.07				
★08-00237-40500	12			60	9,000	12.98	13.54	14.15	14.82	16.38						
★08-00237-40501	16			60	9,000	17.15	17.89	18.71	19.61	21.69						
★08-00237-40503	24	70		10,000	25.49	26.61	27.83	29.18	Free							
★08-00237-40505	32	70		10,000	33.83	35.33	36.96	Free	Free							
★08-00237-41006	8	R1		8	60	9,000	8.79	9.13	9.52	9.93		10.91				
★08-00237-41000	12			60	9,000	12.96	13.49	14.08	14.72	16.22						
★08-00237-41001	16			60	9,000	17.13	17.85	18.64	19.51	21.53						
★08-00237-41003	24		70	10,000	25.47	26.57	27.76	29.08	Free							
★08-00237-41005	32		70	10,000	33.81	35.28	36.89	Free	Free							
★08-00237-50100	15		5	15	70	12,800	16.25	16.97	17.76	18.63		Free				
★08-00237-50101	20			70	12,800	21.46	22.42	23.46	Free	Free						
★08-00237-50103	40			90	16,000	42.32	Free	Free	Free	Free						
★08-00237-50200	15	R0.2		15	70	12,800	16.24	16.96	17.75	18.61		Free				
★08-00237-50201	20			70	12,800	21.46	22.41	23.45	Free	Free						
★08-00237-50203	40			90	16,000	42.31	Free	Free	Free	Free						
★08-00237-50300	15			R0.3	15	70	12,800	16.24	16.95	17.73		18.59	Free			
★08-00237-50301	20	70			12,800	21.45	22.40	23.43	Free	Free						
★08-00237-50303	40	90			16,000	42.31	Free	Free	Free	Free						
★08-00237-50500	15	R0.5			15	70	12,800	16.23	16.93	17.70	18.55	Free				
★08-00237-50501	20				70	12,800	21.44	22.38	23.41	Free	Free					
★08-00237-50503	40				90	16,000	42.30	Free	Free	Free	Free					
★08-00237-51000	15				R1	15	70	12,800	16.21	16.89	17.63	18.45	Free			
★08-00237-51001	20	70				12,800	21.42	22.34	23.34	Free	Free					
★08-00237-51003	40	90		16,000		42.28	Free	Free	Free	Free						
★08-00237-60104	12	6		12		70	13,000	Free	Free	Free	Free	Free				
★08-00237-60100	18		90	16,500	Free	Free	Free	Free	Free							
★08-00237-60101	24		R0.1	24	90	16,500	Free	Free	Free	Free	Free					
★08-00237-60103	48			110	20,100	Free	Free	Free	Free	Free						
★08-00237-60204	12			R0.2	12	70	13,000	Free	Free	Free	Free	Free				
★08-00237-60200	18				90	16,500	Free	Free	Free	Free	Free					
★08-00237-60201	24		90		16,500	Free	Free	Free	Free	Free						
★08-00237-60203	48		110		20,100	Free	Free	Free	Free	Free						
★08-00237-60304	12		R0.3	12	70	13,000	Free	Free	Free	Free	Free					
★08-00237-60300	18			90	16,500	Free	Free	Free	Free	Free						
★08-00237-60301	24			90	16,500	Free	Free	Free	Free	Free						
★08-00237-60303	48			110	20,100	Free	Free	Free	Free	Free						
★08-00237-60504	12			R0.5	12	70	13,000	Free	Free	Free	Free	Free				
★08-00237-60500	18				90	16,500	Free	Free	Free	Free	Free					
★08-00237-60501	24				90	16,500	Free	Free	Free	Free	Free					
★08-00237-60503	48				110	20,100	Free	Free	Free	Free	Free					
★08-00237-61004	12		R1		12	70	13,000	Free	Free	Free	Free	Free				
★08-00237-61000	18				90	16,500	Free	Free	Free	Free	Free					
★08-00237-61001	24				90	16,500	Free	Free	Free	Free	Free					
★08-00237-61003	48				110	20,100	Free	Free	Free	Free	Free					

S チタン合金
耐熱合金 Titanium Alloy Heat Resistant Alloy

H 高硬度鋼 Hardened Steel

~55 HRC

~65 HRC



MHRH430R

切削条件参考表

Recommended Milling Conditions

被削材 Work Material			調質鋼 Prehardened Steels HPM・NAK (~42HRC)				高硬度鋼 Hardened Steels HPM38・STAVAX・SKD61 (~55HRC)				高硬度鋼 Hardened Steels SKD11・PD613 (~62HRC)				ハイス High Speed Steels SKH (~65HRC)					
外径 Dia.	コーナ半径 Corner Radius	首下長 Under Neck Length	回転数 Spindle Speed		送り速度 Feed		切込み量 Depth of Cut		回転数 Spindle Speed		送り速度 Feed		切込み量 Depth of Cut		回転数 Spindle Speed		送り速度 Feed		切込み量 Depth of Cut	
			min ⁻¹	mm/min	a _p mm	a _e mm	min ⁻¹	mm/min	a _p mm	a _e mm	min ⁻¹	mm/min	a _p mm	a _e mm	min ⁻¹	mm/min	a _p mm	a _e mm		
2	0.05 0.1 0.2 0.3 0.5	4	24,000	2,800	0.13	0.7	20,000	2,300	0.06	0.6	17,000	2,000	0.05	0.5	14,000	1,400	0.03	0.35		
		6	22,000	2,500	0.12	0.7	18,000	2,100	0.06	0.6	15,000	1,800	0.05	0.5	12,000	1,300	0.03	0.35		
		8	20,000	2,200	0.11	0.7	16,000	1,800	0.05	0.6	14,000	1,500	0.04	0.5	11,000	1,100	0.02	0.35		
		12	16,000	1,700	0.09	0.7	13,000	1,400	0.04	0.6	11,000	1,200	0.03	0.5	9,000	850	0.01	0.35		
		16	14,000	1,400	0.07	0.7	11,000	1,100	0.03	0.6	9,500	950	0.02	0.5	7,500	650	0.007	0.35		
		20	10,000	800	0.05	0.7	8,000	650	0.02	0.6	7,000	550	0.01	0.5	5,500	400	0.005	0.35		
2.5	0.1 0.2 0.3 0.5	10	16,000	2,200	0.14	0.85	13,000	1,800	0.07	0.7	11,000	1,500	0.05	0.5	9,000	1,100	0.03	0.5		
		20	11,000	1,400	0.08	0.85	9,000	1,100	0.04	0.7	7,500	950	0.02	0.5	6,000	650	0.01	0.5		
		30	7,000	800	0.03	0.85	5,500	650	0.01	0.7	4,500	550	0.01	0.5	3,500	400	0.005	0.5		
3	0.05 0.1 0.2 0.3 0.5 1	4	18,000	2,800	0.18	1	15,000	2,300	0.1	0.8	13,000	2,000	0.07	0.7	10,000	1,400	0.05	0.6		
		6	16,000	2,500	0.17	1	13,000	2,100	0.1	0.8	11,000	1,800	0.07	0.7	9,000	1,300	0.05	0.6		
		8	14,000	2,200	0.16	1	11,000	1,800	0.1	0.8	9,500	1,500	0.07	0.7	7,500	1,100	0.05	0.6		
		12	13,500	2,000	0.16	1	11,000	1,600	0.08	0.8	9,500	1,400	0.06	0.7	7,500	1,000	0.04	0.6		
		16	12,000	1,800	0.14	1	10,000	1,500	0.07	0.8	8,500	1,300	0.05	0.7	7,000	900	0.03	0.6		
		20	10,000	1,400	0.12	1	8,000	1,100	0.05	0.8	7,000	950	0.04	0.7	5,500	700	0.02	0.6		
		25	9,000	1,200	0.08	1	7,500	1,000	0.04	0.8	6,500	850	0.02	0.7	5,000	600	0.01	0.6		
		30	8,000	800	0.06	1	6,500	650	0.03	0.8	5,500	550	0.02	0.7	4,500	400	0.007	0.6		
4	0.1 0.2 0.3 0.5 1	8	12,000	2,600	0.25	1.4	10,000	2,100	0.15	1.2	8,500	1,800	0.08	1	7,000	1,300	0.06	0.8		
		12	12,000	2,600	0.25	1.4	10,000	2,100	0.15	1.2	8,500	1,800	0.08	1	7,000	1,300	0.06	0.8		
		16	10,000	2,200	0.17	1.4	8,000	1,800	0.1	1.2	7,000	1,500	0.06	1	5,500	1,100	0.05	0.8		
		24	8,000	1,600	0.14	1.4	6,500	1,300	0.08	1.2	5,500	1,100	0.05	1	4,500	750	0.03	0.8		
		32	6,500	1,300	0.08	1.4	5,500	1,100	0.04	1.2	4,500	950	0.02	1	3,500	650	0.01	0.8		
5	0.1 0.2 0.3 0.5 1	15	9,500	2,400	0.25	2.2	8,000	2,000	0.15	2	7,000	1,700	0.08	1.6	5,500	1,200	0.06	1.2		
		20	8,000	2,000	0.18	2.2	6,500	1,600	0.1	2	5,500	1,400	0.07	1.6	4,500	1,000	0.05	1.2		
		40	5,000	1,200	0.09	2.2	4,000	1,000	0.05	2	3,500	850	0.02	1.6	3,000	600	0.01	1.2		
		12	8,000	2,500	0.35	2.7	6,500	2,100	0.18	2.5	5,500	1,800	0.08	2	4,500	1,300	0.06	1.5		
6	0.1 0.2 0.3 0.5 1	18	7,000	2,200	0.3	2.7	5,500	1,800	0.18	2.5	4,500	1,500	0.08	2	3,500	1,100	0.06	1.5		
		24	6,000	1,800	0.2	2.7	5,000	1,500	0.15	2.5	4,000	1,300	0.07	2	3,000	900	0.05	1.5		
		48	3,000	900	0.1	2.7	2,500	750	0.05	2.5	2,000	650	0.03	2	2,000	450	0.02	1.5		
備考 Notes			<p>※ 1 実際の加工形状および使用機械等にて切削条件を調整してください。</p> <p>※ 2 切込み量の、a_pは軸方向の切込み深さ、a_eは半径方向の切込み深さを示します。</p> <p>※ 3 高硬度鋼を切削加工する場合は、オイルミストクーラントをお奨めします。</p> <p>※ 4 Z切込み時のアプローチ方法として、ヘリカル（螺旋）及びランプ（傾斜）での切削加工をお奨めします。</p> <p>※ 5 L（首下長）/D（外径）が8倍を超える場合は立ち壁付近の送り速度を50%以下、切込み量：a_eを30%以下に調整してください。</p> <p>※ 6 溝切削は、切削条件参考表を参考に切込み量：a_p及び送り速度を50%以下に設定し、往復切削をお奨めします。</p> <p>※ 7 びびりが発生する場合は、回転数と送り速度を同じ割合で下げてください。また、主軸回転数が足りない場合も同様に同じ割合で下げてください。</p> <p>※ 1 Adjust milling conditions according to milling shape and machine type.</p> <p>※ 2 a_p: Axial Depth of Cut, a_e: Radial Depth of Cut.</p> <p>※ 3 Recommend to use oil mist coolant for machining hardened steels.</p> <p>※ 4 Recommend to apply helical or ramping for approaching into axial direction.</p> <p>※ 5 Adjust feed rate 50% lower and cutting depth (a_e) 30% lower for milling deep wall area when L/D exceeds 8 for stable milling.</p> <p>※ 6 For slotting, recommend reciprocating milling by adjusting feed & a_p in below 50% of recommended milling condition.</p> <p>※ 7 Reduce both spindle speed and feed at same rate for chattering and also for insufficient spindle speed of a machine.</p>																	

レギュラーライン
無限プレミアム
ロングネックタイプ

Regular Line
MUGEN PREMIUM
Long Neck Type

プリハードン鋼
Prehardened Steel

ステンレス鋼
Stainless Steel

チタン合金
耐熱合金
Titanium Alloy
Heat Resistant Alloy

~55 HRC
~65 HRC
高硬度鋼
Hardened Steel

Coating
コート
Long neck
ロングネック
Long neck
ロングネック
Long neck
ロングネック

Regular Line

MUGEN COATING PREMIUM





無限コーティングプレミアム

無限コーティングプレミアムは、従来の無限コーティングを更に改良し、高硬度鋼直彫り加工時の工具寿命を飛躍的に延ばしたのが無限プレミアムです。被膜硬度、耐酸化性が極めて高く45HRC~65HRCの高硬度鋼に適しています。

[被削材] HAP40 : 粉末ハイス (60HRC)

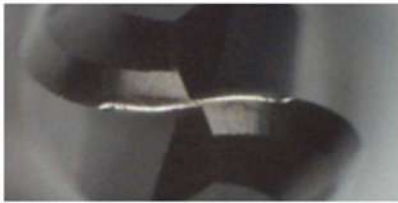

MRBH230 R1x6
摩耗幅0.029mm



他社高硬度用
摩耗幅0.1mm

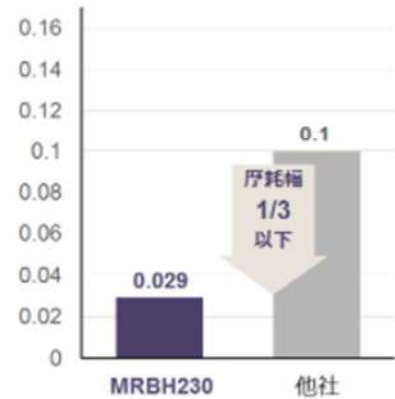

n:20,000min⁻¹ Vf:1,600mm/min ap:0.15mm×ae:0.3mm
オイルミスト 加工時間:18分 切削長25m

[被削材] SKD11 : PD613 (60HRC)



MRBH230 R1x6
摩耗幅0.046mm



他社高硬度用
摩耗幅0.163mm

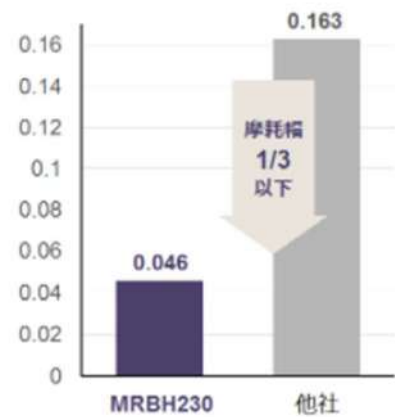

n:25,000min⁻¹ Vf:2,000mm/min ap:0.2mm×ae:0.3mm
オイルミスト 加工時間:62分 切削長100m

MRBH230 によるハイス材 HAP40 直彫り加工



被削材 : HAP40 65HRC

総加工時間 : 9 時間 42 分

高硬度用無限コーティングプレミアムの採用と、オリジナルR部設計により、高硬度鋼加工に切削性&耐久性を実現！

外周刃にバックテーパを採用し、立ち壁部の面精度・面粗さがアップ！

ワークサイズ 30×20(mm)(加工深さ 8mm)

■ 使用工具 : [MRBH230](#)



- 高硬度用の無限コーティングプレミアムと独自の新形状により耐チップング性に優れ、びびりを抑えることにより仕上げ面が向上。
- 65HRC までの高硬度鋼に対応。
- 全 224 サイズ！

■ 切削条件

加工工程	ダイカット部			パンチ部			
	荒取り	側面仕上げ	平面仕上げ	荒取り	側面仕上げ	平面仕上げ	隅R部仕上げ
使用工具	MRBH230 R1×4			MRBH230 R1×8			
回転数 (min ⁻¹)	20,000	20,000	20,000	12,000	12,000	12,000	12,000
送り速度 (mm/min)	2,000	1,200	1,200	900	550	550	550
切込み量 ap×ae(mm)	0.15×0.30	0.02×0.03	0.01×0.02	0.1×0.02	0.02×0.03	0.01×0.02	0.01×0.2
クーラント	オイルミスト						
加工時間	45分	2時間45分		47分	5時間25分		

MHRH430R DVD ケースモデル



被削材 : STAVAX 52HRC

総加工時間 : 12 時間 38 分

無限コーティングプレミアムを採用した
ロングネックラジアスエンドミル、
ステンレス系高硬度鋼の直彫り加工に
においても安定した加工品位が得られます。

ワークサイズ 150×150(mm)

■使用工具

MHRH430R



- 高硬度用の無限コーティングプレミアムと新形状の採用で耐チップング性に優れ、
びびりを抑えることにより仕上げ面が向上。
- 高能率加工が可能な4枚刃タイプ。
- 全336サイズ。

MRBH230



- 高硬度用の無限コーティングプレミアムと独自の新形状により耐チップング性に優れ、
びびりを抑えることにより仕上げ面が向上。
- 65HRCまでの高硬度鋼に対応。
- 全224サイズ。

■切削条件

加工工程	荒取り	中仕上げ	仕上げ	
			側面	底面
使用工具	MHRH430R Φ6×R0.5×24	MRBH230 R1×8	MHRH430R Φ2×R0.5×8	
回転数 (min ⁻¹)	6,000	20,000	40,000	
送り速度 (mm/min)	6,000	2,000	3,000	2,000
切込み量 ap×ae(mm)	0.15×1.5	0.2×0.3	0.02×0.01	0.01×0.03
残し代 (mm)	0.1	0.01	-	
クーラント	オイルミスト			
加工時間	1 時間 40 分	1 時間 58 分	1 時間 30 分	7 時間 30 分